

# Unite Your Audience

The Martin Audio Experience

PRODUCT CATALOGUE



**MTA ELEC CO., LTD**

<https://mtaelec.com>  
[nguyenkien@mtaelec.com](mailto:nguyenkien@mtaelec.com)

Hotline: +84 869 83 68 68

# Unite Your Audience

The Martin Audio Experience







## Sound Adventures

Martin Audio loudspeakers in combination with Astro Spatial Audio software and processing unite your audience in an unrivalled immersive 3D sound field.

Utilising patented acoustic technology the result is scalable and easy to operate fully object-based immersive audio delivering new creative options for live acts and theatres worldwide, as well as installations in a variety of venues.

### FEATURES

- Unite Your Audience with 3D immersive sound fields
- Create movable sound effects and mixes in real time
- Room acoustic enhancement to meet the intended acoustic properties of an event
- Extend stereo image for audience – Wide Stereo
- Integrate with either BlackTrax or Stagetracker II to track performers on stage and improve audio localisation for every member of the audience

### APPLICATIONS

- Live sound events
- Performing art facilities such as theatres and opera houses
- Houses of Worship
- Museum / Art installations
- Theme parks
- Exhibitions
- Corporate Events
- E-Sports Conventions

# V

## V•SERIES

With the V.Series, Martin Audio engineers have designed a range of premium full-range loudspeakers specifically for small-medium scale entertainment installations and family KTV. Three, passive two-way systems — the V.10, V.12 and V.15 — combine the Martin Audio signature sound of warmth, clarity and smooth response with the vocal presence required for a great Karaoke experience.

Each V.Series enclosure features a user-rotatable horn for vertical or horizontal orientation and multiple M8 threaded inserts for easy installation. The trapezoid enclosures are braced internally to reduce panel resonances and improve sonic performance and are finished in a textured black paint, with drivers protected by a perforated steel grille.

Rear ports couple the low-frequency output to walls or ceiling, producing enhanced bass output that can be felt without the need for additional subwoofers. This is particularly useful where space or budget may not allow for subwoofer support. In addition the LF drivers have demodulating rings providing clear, distortion-free vocal reproduction, even at high SPL. And because KTV loudspeakers can be used at high SPL's for many hours, internal crossover networks incorporate technology to protect the low and high frequency drivers and assure reliability without interrupting the performance.

The V.Series takes the performance of compact entertainment loudspeakers to a new level and brings the celebrated signature sound of Martin Audio to premium KTV and bars.





## FEATURES

- Full-range, passive two-way systems
- KTV specific voicing
- Enhanced bass response from rear ports
- LF drivers with demodulating rings for distortion-free vocals
- User-rotatable horns
- Vertical and horizontal mounting option
- Cloth-backed perforated steel grilles
- Trapezoid enclosures with textured finish
- 8Ω nominal impedance
- Internal crossover networks with LF and HF driver protection
- Twin NL4 connectors
- Multiple M8 rigging inserts

## APPLICATIONS

- Family and Premium KTV
- Music bars

## V.10 COMPACT FULL-RANGE SYSTEM



The V.10 is very compact, two-way passive loudspeaker designed for family KTV rooms which call for superior sound over short throw distances. It utilises a 10" (250mm)/2.5" (63mm) voice coil LF driver and a 1" (25mm) exit HF compression driver with a 1.4" (35mm) polyimide diaphragm.

It is capable of high output levels for its small size and its rotatable 90° x 50° HF horn provides extremely smooth coverage. Equal horizontal and vertical horn mouth dimensions ensure its excellent directivity control is maintained in both planes. The V.10's trapezoid enclosure is constructed from 15mm engineered wood fibre and finished in a textured black paint. It is fitted with a cloth-backed protective steel grille and M8 inserts are provided for eyebolt suspension and installation.

## V.12 COMPACT FULL-RANGE SYSTEM



The V.12 is a high-performance, two-way entertainment system. With a maximum SPL of 130dB peak @ 1m, it is ideal for KTV rooms that require high sound levels and vocal clarity from a compact enclosure. It features a 12" (300mm)/2.5" (63mm) voice coil LF driver unit and a 1" (25mm) exit compression driver with a 1.4" (35mm) polyimide diaphragm on a rotatable 80° x 50° HF horn.

It produces impressive low frequency output from its optimised, compact, rear-ported trapezoid enclosure without the need for an additional subwoofer when mounted close to a wall or ceiling. The V.12's trapezoid enclosure is constructed from 15mm engineered wood fibre and fitted with multiple M8 inserts for eyebolt suspension and installation. It is finished in a black textured paint and has a cloth-backed, perforated steel grille to protect the drivers.

## V.15 HIGH-POWER FULL-RANGE SYSTEM



The V.15 is a very high-power, passive two-way system designed for premium KTV installations that demand the ultimate performance and output from a single enclosure.

It features a powerful 15" (380mm)/3" (75mm) voice coil LF drive unit, and a 1" (25mm) exit HF compression driver with a 1.75" (44mm) polyimide diaphragm for extended high frequency response. Its 80° x 50° coverage pattern is ideal for medium-throw applications, and it delivers superior vocal performance at very high sound levels without harshness. Twin rear ports couple with adjacent walls and ceiling to enhance low frequency output and extension.

The enclosure of the V.15 is constructed from 18mm engineered wood fibre and finished in black textured paint. A cloth-backed protective steel grille protects the drivers, and M8 inserts are provided for eyebolt suspension and installation.





## TECHNICAL SPECIFICATIONS

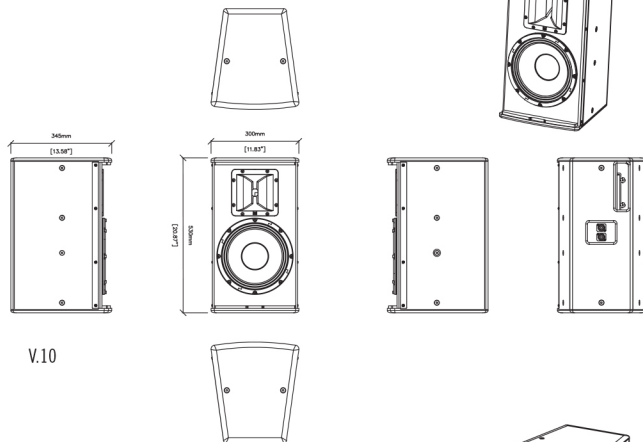

V.10

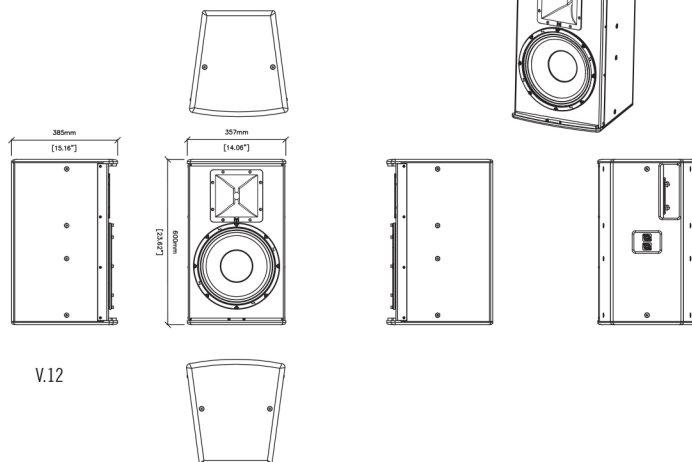

V.12

## V.10

TYPE	Compact, passive two-way system
FREQUENCY RESPONSE (1)	65Hz-20kHz $\pm$ 3dB -10dB @ 49Hz
DRIVERS	LF: 10" (250mm)/2.5" (63.5mm) voice coil, ferrite motor system HF: 1" (25mm) exit/1.4" (35mm) voice coil, polyimide dome compression driver
RATED POWER (2)	500W program, 1000W peak
RECOMMENDED AMP	VIA2502
SENSITIVITY (8)	98dB
MAXIMUM SPL (9)	125dB program, 128dB peak
NOMINAL IMPEDANCE	8 ohms
DISPERSION (-6dB)	90° H x 50° V (user-rotatable)
CROSSOVER	2.8kHz passive
ENCLOSURE	Trapezoid
FINISH	Black textured paint
PROTECTIVE GRILLE	Black perforated steel with scrim cloth backing
CONNECTORS	2 x NL4 type
PIN CONNECTIONS (INPUT)	1+/-
PIN CONNECTIONS (LINK)	1+/- to 1+/-
FITTINGS	14 x M8 inserts
DIMENSIONS	(W) 300mm x (H) 530 x (D) 345mm (W) 11.8ins x (H) 20.9ins x (D) 13.6ins
WEIGHT	16kg (35.3lbs)

## V.12

TYPE	Compact, passive two-way system
FREQUENCY RESPONSE (1)	62Hz-20kHz $\pm$ 3dB -10dB @ 47Hz
DRIVERS	LF: 12" (300mm)/2.5" (63.5mm) voice coil, ferrite motor system HF: 1" (25mm) exit/1.4" (35mm) voice coil, polyimide dome compression driver
RATED POWER (2)	600W program, 1200W peak
RECOMMENDED AMP	VIA5002
SENSITIVITY (8)	99dB
MAXIMUM SPL (9)	127dB program, 130dB peak
NOMINAL IMPEDANCE	8 ohms
DISPERSION (-6dB)	80° H x 50° V (user-rotatable)
CROSSOVER	2.5kHz passive
ENCLOSURE	Trapezoid
FINISH	Black textured paint
PROTECTIVE GRILLE	Black perforated steel with scrim cloth backing
CONNECTORS	2 x NL4 type
PIN CONNECTIONS (INPUT)	1+/-
PIN CONNECTIONS (LINK)	1+/- to 1+/-
FITTINGS	14 x M8 inserts
DIMENSIONS	(W) 357mm x (H) 600mm x (D) 385mm (W) 14.1ins x (H) 23.6ins x (D) 15.2ins
WEIGHT	21kg (46.3lbs)

## V.15

TYPE	High-power, passive two-way system
FREQUENCY RESPONSE (1)	56Hz-20kHz ± 3dB -10dB @ 40Hz
DRIVERS	LF: 15" (380mm)/3" (75mm) voice coil, ferrite motor system HF: 1" (25mm) exit/1.7" (44mm) voice coil, polyimide dome compression driver
RATED POWER (2)	1000W program, 2000W peak
RECOMMENDED AMP	VIA5002
SENSITIVITY (8)	100dB
MAXIMUM SPL (9)	130dB program, 133dB peak
NOMINAL IMPEDANCE	8 ohms
DISPERSION (-6dB)	80° H x 50° V (user-rotatable)
CROSSOVER	2.3kHz passive
ENCLOSURE	Trapezoid
FINISH	Black textured paint
PROTECTIVE GRILLE	Black perforated steel with scrim cloth backing
CONNECTORS	2 x NL4 type
PIN CONNECTIONS (INPUT)	1+/-1-
PIN CONNECTIONS (LINK)	1+/- to 1+/-
FITTINGS	10 x M8 inserts
DIMENSIONS	(W) 419mm x (H) 700mm x (D) 445mm (W) 16.5ins x (H) 27.6ins x (D) 17.5ins
WEIGHT	31kg (68.3lbs)

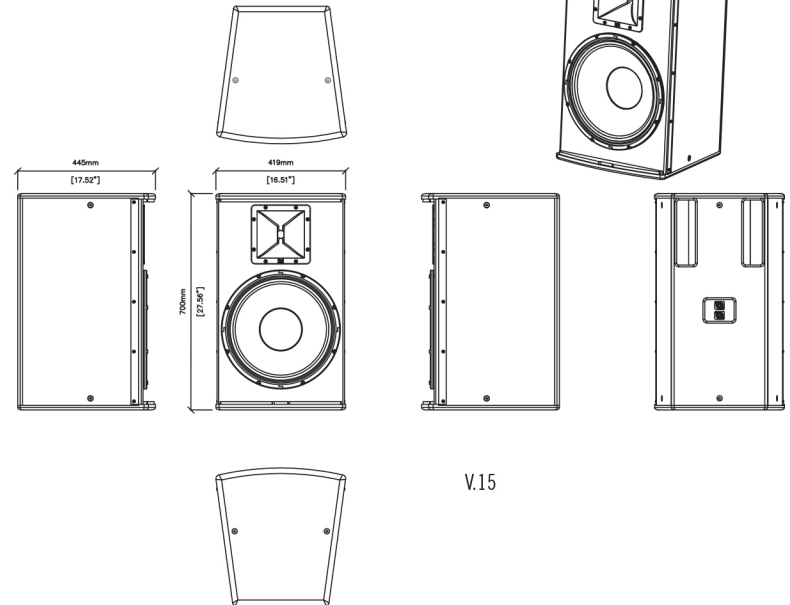

### Notes

- (1) Measured on-axis in half (2pi) space at 2 metres, then referred to 1 metre.
- (2) AES Standard ANSI S4.26-1984.
- (3) Measured in half (2pi) space at 2 metres with 1 watt input, using band limited pink noise, then referred to 1 metre.
- (4) Measured in half (2pi) space at 2 metres using band limited pink noise, then referred to 1 metre.
- (5) Measured on-axis in open (4pi) space at 2 metres, then referred to 1 metre.
- (6) Measured in open (4pi) space at 2 metres with 1 watt input, using band limited pink noise, then referred to 1 metre.
- (7) Measured in open (4pi) space at 2 metres using band limited pink noise, then referred to 1 metre.
- (8) Measured in open (4pi) space at 2 metres with 2.83v input, using band limited pink noise, then referred to 1 metre.
- (9) Calculated at 1 metre.
- (10) Measured in half (2pi) space at 2 metres with 2.83V input, using band limited pink noise, then referred to 1 metre.

# SARA II

## Premium Rendering Engine



### AUDIO AND CONTROL

Audio inputs	32 standard (expandable)
Audio outputs	64 standard (expandable)
Sample rate	24 bit @ 48 kHz
Latency	<5 ms
External Control	Open Sound Control (OSC) for MIDI, RS232 and GPIO
Front panel display	2.8" TFT LCD color touch screen
Standard: MADI	1 x Optical (SC) and coaxial (BNC)
Option: Dante™	1 x RJ45 Gigabit Ethernet LAN port
Wordclock	Selectable internal / external (BNC)
Network	1 x Gigabit on Ethercon Neutrik NE8
Maintenance only	1 x VGA, 1024 x 768 or higher 2 x USB 3.0, 1 x RJ45 Gigabit Ethernet

### STORAGE

RAM	16 GB
Internal storage	2 x 120 GB Solid State Drives
Redundancy	RAID 1 SSD (internal) / Optional parallel SARA II ENGINES
Power Supply	
Input voltage	100 – 240 Vac, 50-60 Hz, 6.3 A max
Max Output	450 W
Connector	Neutrik PowerCon NAC3MPA-1
Option	Redundant PSU, 2 x 500 W, 8 A with audible and visual warnings
GENERAL	
Housing	19" Rackmount, 3 RU
Dimensions	WxDxH 482 x 550 x 132 mm (19" x 21.7" x 5.25")
Weight	11.9 kg (26 lbs) plus cables
Operating System	Linux CentOS





Sziget Festival, Hungary

## Multi-cellular Loudspeaker Array (MLA®) Systems



With multiple awards for innovation, the MLA Series — comprising MLA, MLA Compact and MLA Mini — represents the first fundamental change in array technology since the introduction of line array over twenty years ago.

MLA's combination of cellular drive and automated numerical optimisation delivers much more consistent sound across the audience, puts an end to trial-and-error tuning sessions and reduces sound spill — both on stage and beyond the audience boundary.

MLA technology is a departure from the principles behind conventional line arrays, where the focus is on producing coherent wavefronts as they exit the speaker grilles — giving the user little control over what reaches the ears of the audience. MLA cellular technology takes the opposite approach — the user specifies the SPL and frequency response required at the front rows, the mix position and the rear seats, and intelligent optimisation software automatically determines the array configuration and controls each individual cell in the array to produce that result.

The MLA Series offers new solutions — the MLA touring system resolves the conflicting requirements of audience and local residents at outdoor festivals by delivering the highest sound levels out-front without exceeding strict noise pollution levels off-site. At the other end of the scale, the versatile MLA Mini opens up a wide range of portable live sound applications for smaller venues, as well as a myriad of installation opportunities.

## MLA Cellular Technology

MLA, MLA Compact and MLA Mini all feature cellular drive — where each LF, MF and HF cell in the array has its own onboard DSP and amplification under the control of DISPLAY™ automated intelligent software. A 24-box MLA system will have 144 individual cells, a 16-box MLA Compact system will have 80 cells, and a 16-box MLA Mini will have 32 cells.

With each cell in the array under computer control, MLA Series systems are not constrained by the 3dB decrease in SPL with doubling of distance associated with conventional line arrays — enabling the engineer's exact mix to be delivered throughout the audience with a degree of control, consistency and repeatability not previously possible.

'Hard avoid' areas, such as on-stage, ceilings, balcony edges and beyond the venue perimeter can be programmed in and vertical coverage can also be fine-tuned after rigging without the need to reposition the array or change the inter-cabinet splay angles.

By departing from line array convention, and focusing on what arrives at the audience instead of what leaves the array, MLA cellular technology holds both SPL and frequency response within a very tight window – from the front rows to the rear balconies.

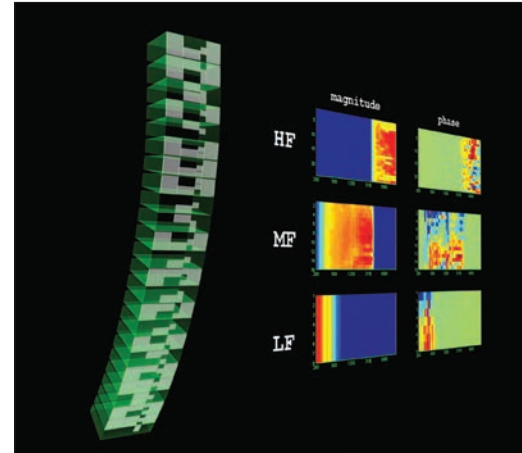

MLA cellular drive

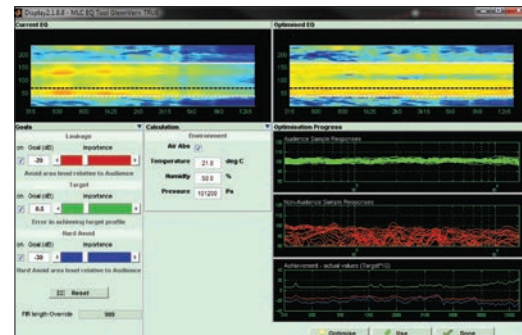

Automated optimisation

## MLA System

MLA system components comprise the MLA 3-way array enclosure, MLD downfill and MLX Sub-bass. MLA is a fully-integrated system, with Class D amplification, U-NET™ control network and DSP all integrated within each enclosure – simplifying set-up and eliminating long, heavy-gauge cable runs.

An MLA touring system is complete and ready-to-use, with enclosures, flying hardware, software, cabling, flight cases and training all included in the system package.

### FEATURES

- Cellular array with built-in amplification, DSP and digital networking
- 6 dedicated Class D amplifier channels per enclosure for individual powering and DSP control of individual cells
- Switch mode power supply with PFC (Power Factor Correction) and global mains voltage operation
- Three-way all-horn design delivers LF/MF/HF peak SPL's of 140/139/145 dB @ 1m from a single enclosure
- Fast, integral flying system for suspension of up to 24 enclosures
- True 90° (-6dB) horizontal constant directivity, mid and high frequency pattern control. Consistent and usable out to 120° (-10dB)
- 60Hz-18kHz ± 3dB full bandwidth frequency response

### APPLICATIONS

- Large-scale touring sound reinforcement for outdoor festivals, stadiums, arenas and concert halls
- Premium fixed installations in concert halls, theatres and sports venues



MLA array

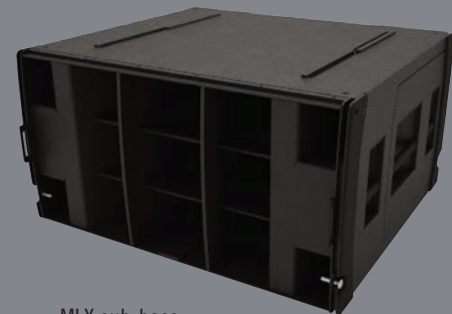

MLX sub-bass

## MLA Compact

Scalable and versatile, MLA Compact brings MLA technology to the wide range of applications that do not require the full power and throw of the MLA. Its compact size belies its output capabilities – a 12-box MLA Compact array can easily deliver full rock SPL's in a 5000 seat venue, whilst a 24-box array will approach the output of many 'full-size' systems.

The MLA Compact is partnered by either the DSX ground-stacked, powered sub-bass, or the DSX-F flying version.

### FEATURES

- Cellular array with built-in amplification, DSP and digital networking
- 5 dedicated Class D amplifier channels per enclosure for individual powering and DSP control of individual cells
- Switch mode power supplies with PFC (Power Factor Correction) and global mains voltage operation
- Three-way all-horn design delivers LF/MF/HF peak SPL's of 135/135/135 dB @ 1m from a single, compact enclosure
- Fast, integral flying system for suspension of up to 24 enclosures
- True 100° (-6dB) horizontal constant directivity, mid and high frequency pattern control. Consistent and usable out to 130° (-10dB)
- 65Hz-18kHz  $\pm$  3dB full bandwidth frequency response

### APPLICATIONS

- Premium touring sound reinforcement for medium-size venues
- Fixed installations in concert halls, theatres, ballrooms and HoW
- Side hang for MLA festival and arena systems

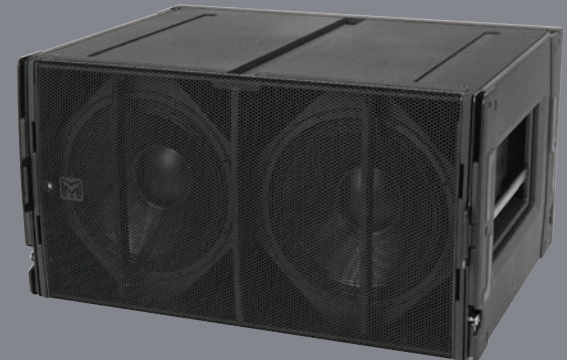
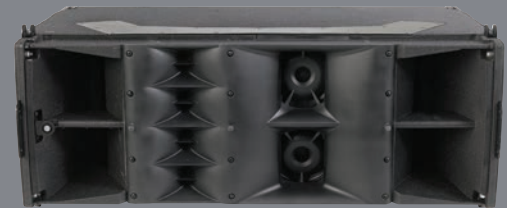
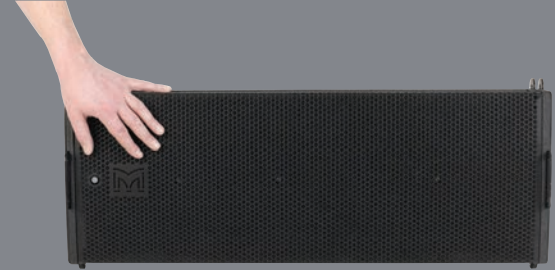

## MLA Mini

The ultra-compact MLA Mini brings revolutionary MLA cellular technology to smaller-scale portable and installed sound applications. Its very small footprint and light weight make it the system of choice for small-to-medium venues. MLA Mini is designed as a complete system, with complementary MSX mini-sub power plant, which houses networking, DSP and 9 channels of Class D amplification necessary to power and control itself and 4 MLA Mini enclosures. MLA Mini can also operate as a plug-and-play system using onboard presets instead of computer control.

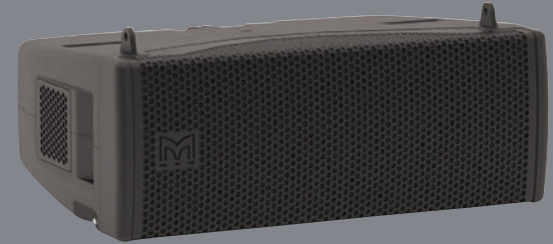

### FEATURES

- Cellular array format with amplification, DSP and digital networking housed in companion MSX sub-bass
- 2 Class D amplifier channels per enclosure for individual powering and DSP control of LF and HF cells
- Switched mode power supplies with PFC (Power Factor Correction) and global mains voltage operation
- Two-way design delivers LF/HF peak SPL's of 130/129dB @ 1m from a single, ultra-compact enclosure
- Fast, integral flying system for suspension of up to 16 MLA Minis
- True 100° (-6dB) horizontal constant directivity
- 76Hz-18kHz  $\pm$  3dB frequency response
- Scalable for audiences of 100-3,000

### APPLICATIONS

- Small-to-medium scale live music venues and theatres
- Portable live sound and AV events
- Fixed installations in concert halls, theatres, ballrooms and HoW
- Side-fill for MLA Compact systems







# Optimised Line Array Systems

In recent years, Martin Audio's award-winning MLA systems have raised the expectations of audiences, sound engineers and promoters worldwide. With independent drive of individual acoustic cells controlled by industry-leading DISPLAY™ optimisation software, MLA technology delivers unmatched sound quality and coverage consistency while reducing sound-spill.

Drawing on the research and technology behind MLA, the Wavefront Precision Series is a new generation of multipurpose line arrays designed to bring Martin Audio's legendary sound, coverage consistency and control to a broader range of touring applications, installations and budgets.

Comprising of WPL, WPC, WPS and WPM, Wavefront Precision line arrays are designed as complete systems with external iKON® multi-channel amplifiers and optimised by automated DISPLAY software.

Adopting the principle of scalable resolution, with external, dedicated multi-channel amplifiers, Wavefront Precision line arrays are uniquely flexible, upgradeable and financially accessible.



THE QUEEN'S AWARDS  
FOR ENTERPRISE:  
INNOVATION  
2021



## WPL

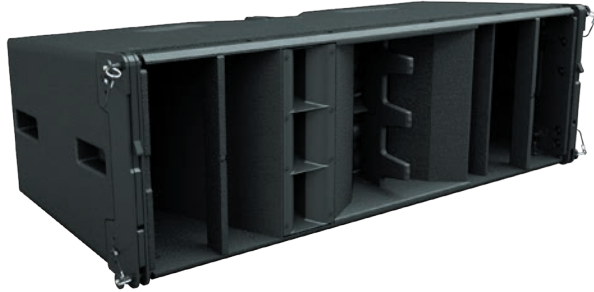

WPL is a full-scale line array which is capable of exceptionally high output for its modest size and weight. A three-way, bi-amped system, its very high output is achieved by utilising Martin Audio's trademark horn-loading technology across all frequency bands — increasing the acoustic output of the low frequency section, as well as the midrange and HF.

It incorporates 2 x 12" (300mm) drivers with Hybrid® horn/reflex loading, 2 x 6.5" (165mm) cone drivers on a midrange horn which covers the vocal frequency range from 300Hz to 4kHz, and 3 x 1" (25mm) exit HF drivers operating from 4kHz upwards. Each section features innovative horn-loading techniques and refinements which raise the acoustic performance of WPL to a superior level — both in terms of output and smooth 90° horizontal coverage patterns of the mid and HF horns. Sonically, WPL's exemplary horizontal dispersion pattern translates to an incredibly consistent frequency response off-axis, with minimal variation from the on-axis response.

The maximum peak outputs of the LF, Mid and HF sections are 139dB, 140dB and 145dB per enclosure @ 1m and 6dB crest factor, respectively — ensuring that a WPL array will meet the most demanding requirements for throw and clarity in the largest venues and outdoor events.

## WPC



The WPC is a three-way, bi-amp system, featuring horn-loaded low-frequency, mid and HF sections to raise efficiency and increase output. The low frequency section consists of 2 x 10" (250mm) neodymium drivers in a unique Hybrid® configuration which marries the benefits of horn and reflex loading. Each driver is slot-loaded into a short horn to give a high sensitivity of 103dB @ 1m/2.83V, while the rear of the driver is reflex-loaded to extend the LF output. The punch and low-frequency extension produced from such a small enclosure volume are remarkable.

Mid and HF horns are physically separate — a key factor in WPC's exemplary 100° horizontal constant directivity dispersion pattern. The midrange horn design utilises 2 x 5" (125mm) neodymium drivers to produce a high SPL of 109dB @ 1m/2.83V, while the HF section employs 4 x 0.7" (19mm) exit neodymium compression drivers which feed 4 individual horns. Use of multiple small HF drivers instead of a more traditionally-used large format compression driver results in less distortion and a more extended HF response.

## WPS



A passive 3-way system which integrates a high density of drive units in a very compact enclosure. It features 2 x 8" (200mm) LF drivers, 4 x 4" (100mm) midrange drivers and 4 x 1" (25mm) exit HF compression drivers loaded by a moulded HF horn which occupies the full width of the enclosure — defining the 100° horizontal constant directivity coverage pattern of both the HF and midrange sections.

The 4" midrange drivers are compression-loaded to raise efficiency and enter the horn walls via annular slots close to the HF throat to sum effectively with the HF wavefront. In the HF section, four 1" exit compression drivers deliver pristine high frequency sound without the harshness and distortion associated with larger format devices.

The 8" LF drivers are set back behind the walls of the HF horn, with a small volume of air in front of each driver increasing the output at the upper end of its operating range. The LF exit apertures are spaced apart horizontally to provide useful LF horizontal pattern control.

## WPM



A passive 2-way system with an impedance of 16 ohms, it can be driven in blocks of 1, 2, 3 or 4 resolution configuration. With a complement of 2 x 6.5" (165mm) LF drivers and a vertical column of 3 x 1.4" (35mm) aluminium dome HF drivers, the acoustic design of WPM is uniquely innovative. The LF drivers are located in the side walls of the HF horn — an arrangement which would introduce acoustic cavities which would degrade the horizontal dispersion if conventional cone drivers were used. WPM's drivers adopt an elegant solution by having solid moulded diaphragms which match the contours of the horn walls and maintain the continuity of the horn profile.

Each LF driver also features a demodulation ring in the neodymium motor system to minimize distortion and maximise mid-band output.

In the triple-driver HF section, each individual HF wavefront is precisely coupled to the horn throat via a short waveguide for faultless 100° horizontal constant directivity coverage.

## WPL

<b>TYPE</b>	Three-way, bi-amp line array element
<b>FREQUENCY RESPONSE (5)</b>	52Hz-18kHz $\pm$ 3dB
<b>DRIVERS</b>	LF: 2 x 12" (300mm)/3" (75mm) voice coil, ultra-long excursion, neodymium magnet drivers, Hybrid® bass horn loaded MF: 2 x 6.5" (165mm)/2" (50mm) coil, neodymium magnet drivers, horn loaded HF: 3 x 1" (25mm) exit neodymium magnet compression drivers, horn loaded iKON iK42
<b>SYSTEM AMPLIFIER</b>	
<b>SYSTEM RESOLUTION</b>	1 or 2 enclosures per pair of amplifier channels (Bi-amp)
<b>MAXIMUM SPL (9)</b>	LF: 139dB, MF: 140dB, HF: 145dB
<b>NOMINAL IMPEDANCE</b>	LF: 8 ohms, MF + HF: 8 ohms
<b>DISPERSION</b>	90° horizontal (-6dB), 120° horizontal (-10dB), 7.5° vertical
<b>CROSSOVER</b>	320Hz active, 4kHz internal passive
<b>ENCLOSURE</b>	Vertical trapezoid with 3.75° wall angle, multi-laminate birch and poplar-ply construction
<b>FINISH</b>	Black textured paint
<b>PROTECTIVE GRILLE</b>	Black HEX perforated steel
<b>DIMENSIONS (ex. pins)</b>	(W) 1136mm x (H) 371mm x (D) 526mm (W) 44.7in x (H) 14.6in x (D) 20.7in
<b>WEIGHT</b>	64kg (141lbs)



## WPS

<b>TYPE</b>	Three-way, passive line array element
<b>FREQUENCY RESPONSE (5)</b>	70Hz-18000Hz $\pm$ 3dB
<b>DRIVERS</b>	LF: 2 x 8" (200mm)/2" (50mm) voice coil, long excursion, vented yoke, neodymium magnet drivers MF: 4 x 4" (100mm)/1" (25mm) coil, neodymium magnet drivers, compression loaded HF: 4 x 1" (25mm) exit/1.4" (35mm) HT Polymer diaphragm, neodymium magnet compression drivers iKON iK42
<b>SYSTEM AMPLIFIER</b>	
<b>SYSTEM RESOLUTION</b>	1 to 3 enclosures per amplifier channel (iK42)
<b>MAXIMUM SPL (9)</b>	133dB peak
<b>NOMINAL IMPEDANCE</b>	6 ohms
<b>DISPERSION</b>	100° horizontal (-6dB), 120° horizontal (-10dB), 10° vertical
<b>CROSSOVER</b>	520Hz, 1.6kHz internal passive
<b>ENCLOSURE</b>	Vertical trapezoid with 5° wall angle, multi-laminate birch and poplar-ply construction
<b>FINISH</b>	Black textured paint
<b>PROTECTIVE GRILLE</b>	Black HEX perforated steel
<b>FITTINGS</b>	3-point rigging system, 2 x side pocket handles 2 x rear grip handles
<b>DIMENSIONS</b>	(W) 650mm x (H) 261mm x (D) 400mm (W) 25.6in x (H) 10.3in x (D) 15.8in
<b>WEIGHT</b>	27kg (60lbs)



## WPC

<b>TYPE</b>	Three-way, bi-amp line array element
<b>FREQUENCY RESPONSE (5)</b>	65Hz-18kHz $\pm$ 3dB
<b>DRIVERS</b>	LF: 2 x 10" (250mm)/2.5" (63mm) voice coil, long excursion, vented pole, neodymium magnet drivers, Hybrid® slot-horn loaded MF: 2 x 5" (125mm)/1.5" (38mm) coil, neodymium magnet drivers, horn loaded HF: 4 x 0.7" (18mm) exit neodymium magnet compression drivers, horn loaded iKON iK42
<b>SYSTEM AMPLIFIER</b>	
<b>SYSTEM RESOLUTION</b>	1 to 3 enclosures per pair of amplifier channels (Bi-amp)
<b>MAXIMUM SPL (9)</b>	135dB peak
<b>NOMINAL IMPEDANCE</b>	LF: 8 ohms, MF + HF: 8 ohms
<b>DISPERSION</b>	100° horizontal (-6dB), 130° horizontal (-10dB), 10° vertical
<b>CROSSOVER</b>	440Hz active, 4.4kHz internal passive
<b>ENCLOSURE</b>	Vertical trapezoid with 5° wall angle, multi-laminate birch and poplar-ply construction
<b>FINISH</b>	Black textured paint
<b>PROTECTIVE GRILLE</b>	Black HEX perforated steel
<b>DIMENSIONS</b>	(W) 772mm x (H) 319mm x (D) 421mm (W) 30.4in x (H) 12.6in x (D) 16.6in
<b>WEIGHT</b>	35kg (77.1lbs)



## WPM

<b>TYPE</b>	Two-way, passive line array element
<b>FREQUENCY RESPONSE (5)</b>	76Hz-18kHz $\pm$ 3dB
<b>DRIVERS</b>	LF: 2 x 6.5" (165mm) contoured-diaphragm /2" (50mm) edge-wound CCAW voice coil, neodymium magnet drivers, reflex loaded HF: 3 x 1.4" (35mm) aluminium dome /1.4" (35mm) voice coil, neodymium magnet compression drivers on constant-directivity waveguide iKON iK42, iK81
<b>SYSTEM AMPLIFIER</b>	
<b>SYSTEM RESOLUTION</b>	1 to 4 enclosures per amplifier channel
<b>MAXIMUM SPL (9)</b>	130dB peak (1 cabinet)
<b>NOMINAL IMPEDANCE</b>	16 ohms
<b>DISPERSION</b>	100° horizontal (-6dB), 125° horizontal (-10dB), 10° vertical
<b>DIMENSIONS</b>	(W) 500mm x (H) 185mm x (D) 377mm (W) 19.7in x (H) 7.3in x (D) 14.8in
<b>WEIGHT</b>	14kg (30.9lbs)



## iK81

<b>General</b>	
TYPE	Eight-channel Class D amplifier
TOTAL OUTPUT POWER	10,000 Watts RMS, all channels driven
DIGITAL SIGNAL PROCESSING	96kHz DSP on all inputs and outputs
COOLING	Dual vari-speed fans, front-to-back airflow
MAXIMUM AMBIENT TEMPERATURE	40°C (104°F)
<b>Audio Inputs/Outputs</b>	
ANALOGUE IN/LINK (4 CHANNELS)	4 x female, 4 x male Neutrik™ XLR
ANALOGUE INPUT IMPEDANCE	20k $\Omega$ balanced to ground
MAXIMUM ANALOGUE INPUT LEVEL	+20dBu
NOMINAL SYSTEM GAIN	32dB
AES3 IN/LINK (2 CHANNELS)	1 x female, 1 x male Neutrik™ XLR, balanced
DANTE™ (4 CHANNELS)	2 x shielded RJ45, primary and secondary
AMPLIFIER OUTPUTS	4 x Neutrik Speakon™ NL4
<b>Control and Monitoring Network</b>	
TOPOLOGY	Ethernet
CONTROL APPLICATION	Martin Audio VU-NET™
<b>Power Supply</b>	
TYPE	High performance Series Resonant
AC INPUT OPERATING RANGE	85 – 240V ~ AC, 47 - 63Hz
MAINS INRUSH CURRENT	6A at 15V, 12A at 230V (max for <10ms)
MAINS CONNECTOR	Neutrik 32A Powercon™
<b>Physical</b>	
DIMENSIONS	(W) 483 x (H) 2U/89mm x (D) 357mm (W) 19in x (H) 2U/3.5in x (D) 14.1in incl handles and optional rear support
WEIGHT	12.5kg (27.5lbs)



## iK42

<b>General</b>	
TYPE	Four-channel Class D amplifier
TOTAL OUTPUT POWER	20,000 Watts RMS, all channels driven
DIGITAL SIGNAL PROCESSING	96kHz DSP on all inputs and outputs
COOLING	Dual vari-speed fans, front-to-back airflow
MAXIMUM AMBIENT TEMPERATURE	40°C (104°F)
<b>Audio Inputs/Outputs</b>	
ANALOGUE IN/LINK (4 CHANNELS)	4 x female, 4 x male Neutrik™ XLR
ANALOGUE INPUT IMPEDANCE	20k $\Omega$ balanced to ground
MAXIMUM ANALOGUE INPUT LEVEL	+20dBu
NOMINAL SYSTEM GAIN	32dB
AES3 IN/LINK (2 CHANNELS)	1 x female, 1 x male Neutrik™ XLR, balanced
DANTE™ (4 CHANNELS)	2 x shielded RJ45, primary and secondary
AMPLIFIER OUTPUTS	4 x Neutrik Speakon™ NL4
<b>Control and Monitoring Network</b>	
TOPOLOGY	Ethernet
CONTROL APPLICATION	Martin Audio VU-NET™
<b>Power Supply</b>	
TYPE	High performance Series Resonant
AC INPUT OPERATING RANGE	85 – 240V ~ AC, 47 - 63Hz
MAINS INRUSH CURRENT	6A at 15V, 12A at 230V (max for <10ms)
MAINS CONNECTOR	Neutrik 32A Powercon™
<b>Physical</b>	
DIMENSIONS	(W) 483 x (H) 2U/89mm x (D) 357mm (W) 19in x (H) 2U/3.5in x (D) 14.1in incl handles and optional rear support
WEIGHT	12.5kg (27.5lbs)





St Andrews Cathedral, Sydney, Australia

## O-Line™

NOW WITH SCALABLE RESOLUTION

O-Line™ is a versatile, micro-line array now with scalable resolution designed to tame a wide variety of architectural and challenging acoustic environments.

O-Line delivers consistent audio coverage with unprecedented accuracy in a wide variety of architectural environments, using just one amplifier channel per array in many applications. By utilising a complement of unique, Martin Audio designed drivers, and mechanical alignment techniques, simple EQ and Limiting is the only processing required.

O-Line is an award winning aesthetically pleasing modular micro line array designed for a wide variety of architectural applications – from houses of worship to transport terminals.

It combines innovative acoustic design with powerful optimisation software to achieve optimum coverage with unprecedented accuracy over a pre-defined area.

In many applications an O-Line array can be driven using only one amplifier channel, with simple EQ and limiting the only processing required.

It can now also be taken into a new dimension of coverage, consistency and control when combined with an iKON iK81 eight-channel amplifier with onboard DSP to independently control and power each individual enclosure. This unlocks the full potential of O-Line — further refining coverage consistency and increasing the ability to ‘dial-out’ the influence of the room by accessing DISPLAY’s ‘hard avoid’ capability and electronically adjustable coverage.

Unlike many DSP ‘steered’ columns, an O-Line array does not produce unwanted vertical sidelobes in the audio band. This is critical in reverberant environments as sidelobes firing above and below the array simply adds to the reverberant energy, impacting on intelligibility. O-line’s ability to reproduce very high frequencies without sidelobes makes it the ideal solution for both full-range speech and music reproduction in reverberant spaces.

An O-Line array is finished in a neutral light grey that blends into the background of most architectural spaces with modular design in multiples of four cabinets. Sonically, it is very clean and musical, and capable of surprisingly high output levels for its very small size with 16 cabinets capable of an astonishing 134dB [peak] and a throw distance of up to 40 metres.

## O-Line™



TYPE	Two-way micro line array module
FREQUENCY RESPONSE (5)	85Hz-20kHz $\pm$ 3dB, -10dB @ 76Hz
DRIVERS	2 x 3.5" (87mm)/1" (25mm) voice coil LF drivers 5 x 0.55" (14mm) soft dome tweeters
RATED POWER (2)	50W AES, 200W peak
SENSITIVITY (8)	84dB at LF rising to 92dB at HF
MAXIMUM SPL (9)	104dB continuous, 110dB peak
NOMINAL IMPEDANCE	16 ohms
DISPERSION (-6dB)	100° horizontal, 5° vertical
CONNECTORS	4 pole socket
FITTINGS	6 x M8 fixings for wall and flying brackets
DIMENSIONS	(W) 246mm x (H) 115mm x (D) 198mm (W) 9.7ins x (H) 4.5ins x (D) 7.8ins
WEIGHT	3.6kg (7.9lbs)

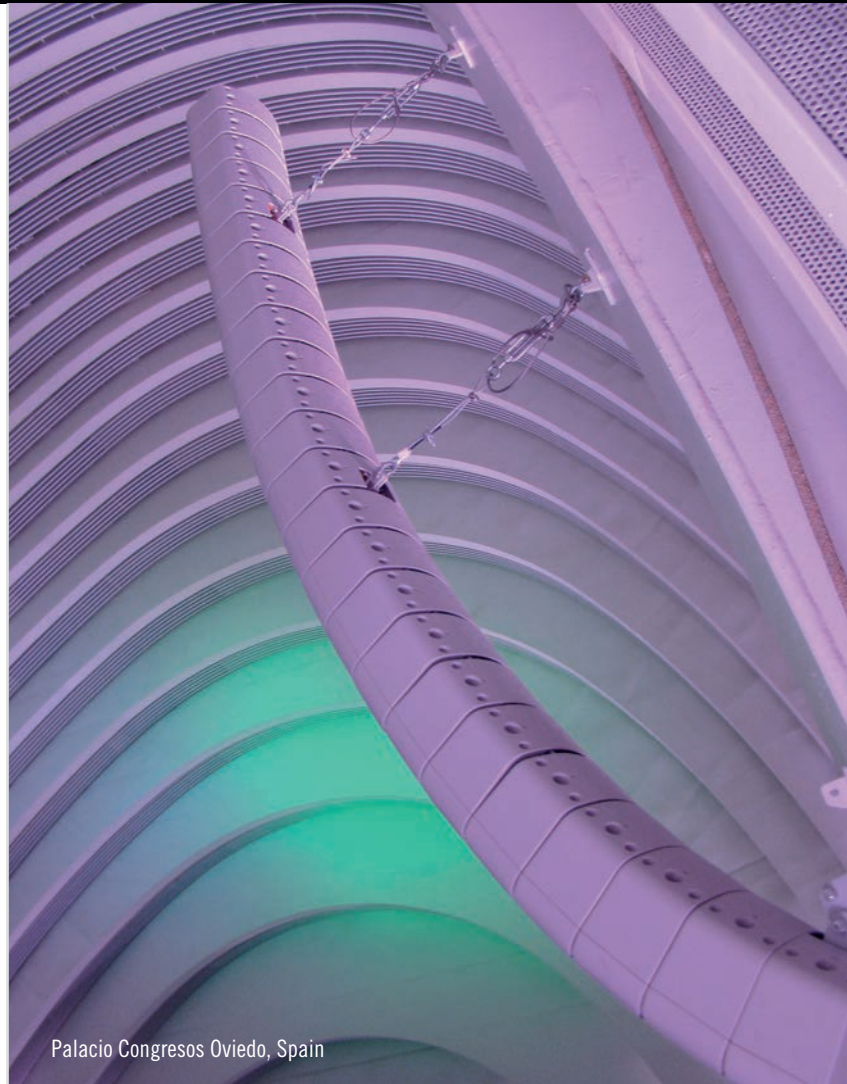

Palacio Congressos Oviedo, Spain



# TORUS

## TORUS – Constant Curvature Array

For applications that typically require a throw between 15-30m (50-100ft), a full-blown line array is not always practical, optimal or affordable. Conversely, a point source solution may not be sufficient in coverage and SPL.

TORUS is a constant curvature array designed to fill that gap, combining optimised coverage, SPL profile and cost efficiency.

Typically, constant curvature arrays have adjustable horizontal dispersion but their performance can vary considerably in terms of tonality and effectiveness of coverage when different dispersions are selected. Equally, many lack sufficient sensitivity in the mid-band frequency, critically important for voice projection and clarity. They also can suffer from comb filtering. TORUS fundamentally addresses these areas and more.

Each TORUS cabinet is designed for a flexible horizontal dispersion pattern and this can be manually adjusted between 90°, 60° or 75° (asymmetrical) via the unique Dynamic Horn Flare™. This not only moves and locks the waveguide but also adjusts the horn mouth, including the low diffraction termination into the baffle, to ensure correct geometry and optimal performance in each of those settings.

The Dynamic Horn Flare™ is moved by a rotating mechanism accessible from the front grille so is easy and intuitive, while leaving the grille design to be both smart and fully protective of the drivers within.

A vertical pattern of either 15° or 30° is achieved via two separate cabinet types: T1215 and T1230, respectively. These cabinets can also be combined to fit venue and coverage requirements.

TORUS features a phase plug mounted in front of the 12" neodymium driver to increase mid-band sensitivity, and along with three 1.4" HF polymer dome neodymium compression drivers, the sonic performance is not compromised even when driven at higher SPL.



# T1230



<b>TYPE</b>	Passive 2-way Constant Curvature 30° enclosure
<b>FREQUENCY RESPONSE</b> (with iKON settings)	65Hz – 18kHz ± 3dB, -10dB @ 50Hz
<b>DRIVERS</b>	LF: 12", 3" Voice Coil, Neodymium HF: 3 x 1" exit, 1.4" Voice Coil, HT Polymer dome neodymium compression driver
<b>SENSITIVITY</b>	(2.83V 1m free-field) 99dB
<b>NOMINAL IMPEDANCE</b>	8 ohms
<b>RATED POWER</b>	AES 400W, PEAK 1600W
<b>MAXIMUM SPL (SYSTEM)</b>	126dB continuous, 132dB peak*
<b>DISPERSION</b>	60-75-90° horizontal, 30° vertical
<b>PIN CONNECTIONS (INPUT)</b>	1 +/- or 2 +/-
<b>PIN CONNECTIONS (LINK)</b>	1 +/- and 2 +/-
<b>DIMENSIONS</b>	(W) 650mm, (H) 350mm, (D) 442mm (W) 25.59ins, (H) 13.76ins, (D) 17.40ins
<b>WEIGHT</b>	26kg (57.32 lbs)

# T1215



<b>TYPE</b>	Passive 2-way Constant Curvature 15° enclosure
<b>FREQUENCY RESPONSE</b> (with iKON settings)	65Hz – 18kHz ± 3dB, -10dB @ 50Hz
<b>DRIVERS</b>	LF: 12", 3" Voice Coil, Neodymium HF: 3 x 1" exit, 1.4" Voice Coil, HT Polymer dome neodymium compression driver
<b>SENSITIVITY</b>	(2.83V 1m free-field) 100dB
<b>NOMINAL IMPEDANCE</b>	8 ohms
<b>RATED POWER</b>	AES 400W, PEAK 1600W
<b>MAXIMUM SPL (SYSTEM)</b>	128dB continuous, 134 dB peak*
<b>DISPERSION</b>	60-75-90° horizontal, 15° vertical
<b>PIN CONNECTIONS (INPUT)</b>	1 +/- or 2 +/-
<b>PIN CONNECTIONS (LINK)</b>	1 +/- and 2 +/-
<b>DIMENSIONS</b>	(W) 650mm, (H) 369mm, (D) 452mm (W) 25.59ins, (H) 14.51ins, (D) 17.80ins
<b>WEIGHT</b>	31kg (68.34 lbs)

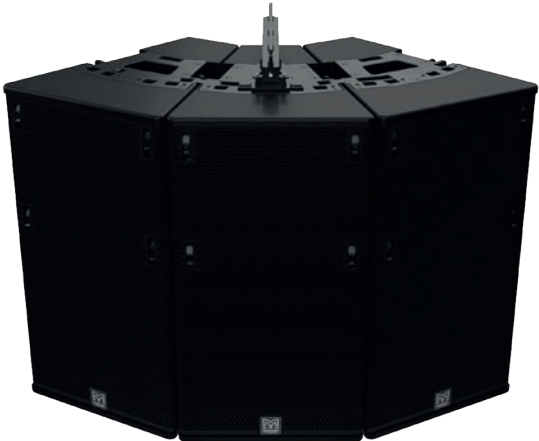

## VU-NET – Control Software

MLA, Wavefront Precision, CDD-LIVE and indeed any U-NET enabled device can all be remotely controlled from a PC or tablet running VU-NET control software. As well as monitoring and control of the system, EQ optimisations are uploaded from the program and cabinet firmware is checked and updated all via the intuitive graphical interface.

Both VU-NET and DISPLAY are free to download programs from the Martin Audio website.

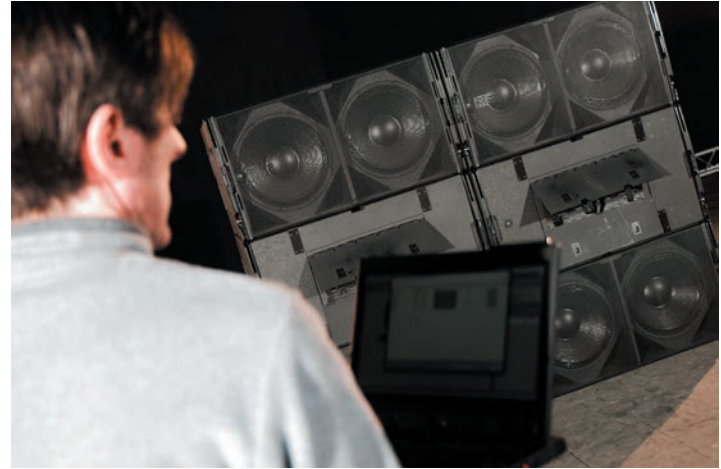

## DISPLAY 2 – Optimisation and Prediction Software

DISPLAY 2 is the brain of the MLA Series, Wavefront Precision Series and O-Line. Its numerical optimisation process eliminates lengthy trial-and-error tuning sessions, so that an MLA or Wavefront Precision system achieves the required audience coverage straight out of the box.

Based on a detailed acoustic model of array behaviour, it gives a very accurate prediction of the direct sound produced over the audience as well as areas where sound is to be reduced.

It takes the guesswork out of array design, deployment and control – generating highly accurate spot frequency responses and comprehensive rigging information, including mechanical load safety analysis.

The intelligent optimisation process evaluates configurations of potential arrays against various target functions — such as frequency response, flatness and sound leakage into non-audience areas. With the computer working behind the scenes, the engineer retains full artistic control over the house curves — DISPLAY 2 simply replicates what the engineer hears at the mix position to the entire audience.\*

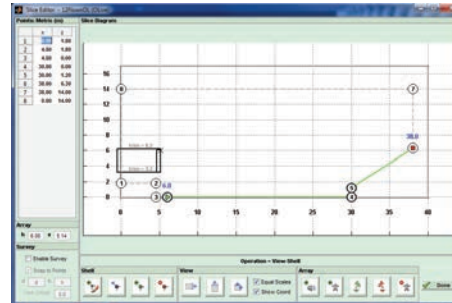

Step 1: Venue entry

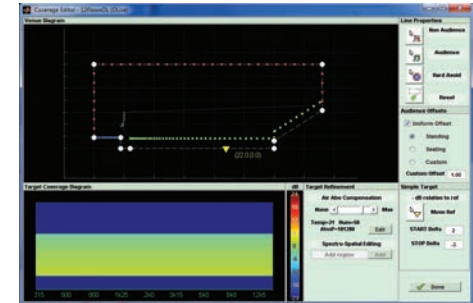

Step 2: Set coverage parameters

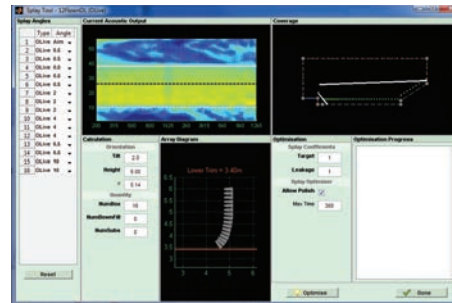

Step 3: Calculate splay angles

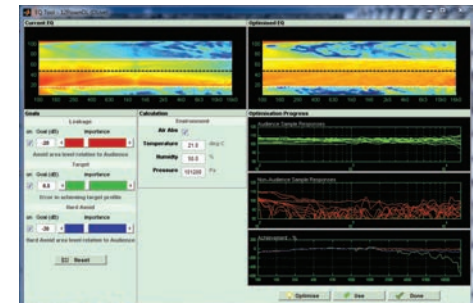

Step 4: Optimisation and upload

\*For Wavefront Precision and O-Line, audience coverage consistency is also dependent upon the level of amplification per box.

## DISPLAY 3 – 3D Prediction Software

DISPLAY 3 is an all-new 3D prediction software program that in time will incorporate all of our current portfolio.

Inheriting a familiar work flow from DISPLAY 2, but now in a fully 3D environment with the ability to also import SketchUp files and add multiple loudspeakers for a full venue or event system design.

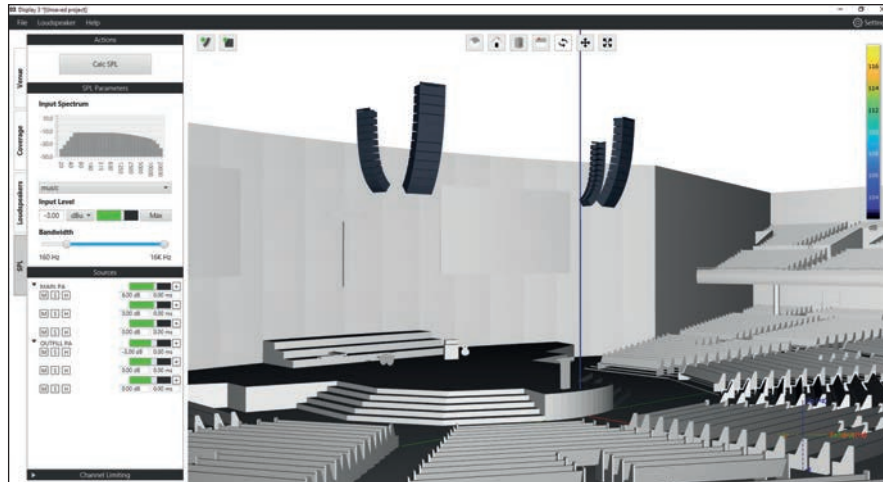



## SX Subwoofers

Martin Audio's SX Series of subwoofers are designed to meet a multitude of installation and live sound application needs that call for increased impact and low frequency performance, partnering with our loudspeakers across the portfolio.

SX subwoofers offer a full complement passive and select self-powered options including everything from a slim line single 10" (SX110) for discreet install purposes through to the all-powerful chest thumping efficiency of the double-eighteen Hybrid® Horn/Reflex SXH218 suitable for concerts, festivals and nightclubs.

## SX110

TYPE	Ultra-compact, direct radiating subwoofer
FREQUENCY RESPONSE (1)	50Hz-150Hz ± 3dB -10dB @ 42Hz
DRIVER	1 x 10" (250mm)/2" (50mm) voice coil, long excursion, ferrite magnet
RATED POWER (2)	250W AES, 1000W peak
RECOMMENDED AMPLIFIER	VIA 2502
SENSITIVITY (10)	97dB
MAXIMUM SPL (9)	121dB continuous, 127dB peak (half space)
NOMINAL IMPEDANCE	8 ohms
DISPERSION (-6dB)	Omnidirectional
CROSSOVER	80-120Hz active
ENCLOSURE	Plywood
FINISH	Black or white
PROTECTIVE GRILLE	Perforated steel
CONNECTORS	2 x NL4 type
PIN CONNECTIONS (INPUT)	+1, -1 Link through: +2, -2
PIN CONNECTIONS (LINK)	+1, -1 Link through: +2, -2
FITTINGS	12 x M8 inserts
DIMENSIONS (INCL FEET)	(W) 417mm x (H) 297mm x (D) 415mm (W) 16.4ins x (H) 11.7ins x (D) 16.3ins
WEIGHT	12kg (26.5lbs)



## SX112

TYPE	Compact, single driver, direct radiating subwoofer
FREQUENCY RESPONSE (1)	48Hz-150Hz ± 3dB, -10dB @ 35Hz
DRIVER	12" (300mm)/3" (75mm) voice coil, long excursion, ferrite magnet, waterproof cone
RATED POWER (2)	400W AES, 1600W peak
RECOMMENDED AMPLIFIER	iK81 / VIA2502/5002/5004
SENSITIVITY (10)	100dB
MAXIMUM SPL (9)	126dB continuous, 132dB peak (half space)
NOMINAL IMPEDANCE	8 ohms
CONNECTORS	2 x NL4 type
FITTINGS	12 x M10 inserts
DIMENSIONS	(W) 487mm x (H) 390mm x (D) 410mm (W) 19.2ins x (H) 15.4ins x (D) 16.1ins
WEIGHT	21.5kg (47.3lbs)



## SX210

TYPE	Slimline, direct radiating subwoofer
FREQUENCY RESPONSE (1)	50Hz-150Hz ± 3dB -10dB @ 42Hz
DRIVER	2 x 10" (250mm)/2" (50mm) voice coil, long excursion, ferrite magnet
RATED POWER (2)	500W AES, 2000W peak
RECOMMENDED AMPLIFIER	VIA 2004/5002/5004
SENSITIVITY (10)	103dB
MAXIMUM SPL (9)	127dB continuous, 133dB peak (half space)
NOMINAL IMPEDANCE	4 ohms
CONNECTORS	2 x NL4 type
FITTINGS	16 x M8 inserts, 2 x bar handles
DIMENSIONS (INCL FEET)	(W) 718mm x (H) 295mm x (D) 465mm (W) 28.3ins x (H) 11.4ins x (D) 18.3ins
WEIGHT	20kg (44.1lbs)



## SX212

TYPE	Compact, dual-driver, direct radiating subwoofer
FREQUENCY RESPONSE (1)	48Hz-150Hz ± 3dB, -10dB @ 35Hz
DRIVER	2 x 12" (300mm)/3" (75mm) voice coil, long excursion, ferrite magnet, waterproof cone
RATED POWER (2)	800W AES, 3200W peak
RECOMMENDED AMPLIFIER	iK42 / VIA5002/5004
SENSITIVITY (10)	106dB
MAXIMUM SPL (9)	132dB continuous, 138dB peak (half space)
NOMINAL IMPEDANCE	4 ohms
CONNECTORS	2 x NL4 type
FITTINGS	12 x M10 inserts
DIMENSIONS	(W) 872mm x (H) 390mm x (D) 437mm (W) 34.3ins x (H) 15.4ins x (D) 17.2ins
WEIGHT	39kg (86lbs)



## SXF115



<b>TYPE</b>	Compact, direct radiating subwoofer
<b>FREQUENCY RESPONSE (1)</b>	50Hz – 150Hz ±3dB, -10dB @ 42Hz
<b>DRIVER</b>	15" (380mm)/4" (100mm) voice coil, ultra-long excursion, ferrite magnet
<b>SYSTEM AMPLIFIER</b>	iKON iK42, iK81
<b>SENSITIVITY (10)</b>	103dB
<b>MAXIMUM SPL(9)</b>	136dB peak
<b>NOMINAL IMPEDANCE</b>	4 ohms
<b>CONNECTOR</b>	2 x NL4
<b>PIN CONNECTIONS (INPUT)</b>	LF: +1, -1 Link through: +2, -2
<b>PIN CONNECTIONS (LINK)</b>	LF: +1, -1 Link through: +2, -2
<b>FITTINGS</b>	Two skids on base, with mating channels on top M20 top-mounted thread plate for pole mounting Integral flyware for suspension of up to 4 SXF115 Large bar handle on each side
<b>DIMENSIONS (INCL SKIDS)</b>	Two front-mounted latch plates for wheelboard (W) 500mm x (H) 509mm x (D) 574mm (725mm incl wheelboard)
<b>WEIGHT</b>	(W) 19.7in x (H) 20in x (D) 22.6in (28.5in incl wheelboard) 45kg (99lbs) 52kg (115lbs) incl wheelboard

## SX118



<b>TYPE</b>	Compact, direct radiating subwoofer
<b>FREQUENCY RESPONSE (1)</b>	47Hz – 150Hz ±3dB, -10dB @ 41Hz
<b>DRIVER</b>	18" (460mm)/4" (100mm) voice coil, long excursion, ferrite magnet, waterproof cone
<b>SYSTEM AMPLIFIER</b>	iKON iK42, iK81
<b>SENSITIVITY (10)</b>	102dB
<b>MAXIMUM SPL(9)</b>	138dB peak
<b>NOMINAL IMPEDANCE</b>	8 ohms
<b>CONNECTORS</b>	2 x NL4
<b>FITTINGS</b>	Two skids on base, with mating channels on top 16 x M8 inserts for optional castors M20 top-mounted thread plate for pole mounting 16 x M10 mounting points 2 x bar handles, 1 on each side 4 x fittings for optional transit cover
<b>DIMENSIONS (INCL SKIDS)</b>	(W) 600mm x (H) 509mm x (D) 632mm (760mm including castors) (W) 24in x (H) 20.36in x (D) 25.26in (30.38in including castors)
<b>WEIGHT</b>	47kg (104lbs) with castors

## SXC115



<b>TYPE</b>	Compact, cardioid subwoofer
<b>FREQUENCY RESPONSE (1)</b>	44Hz – 150Hz ±3dB, -10dB @ 36Hz
<b>DRIVERS</b>	15" (380mm)/4" (100mm) voice coil, long excursion, ferrite magnet, waterproof cone 12" (300mm)/4" (100mm) voice coil, long excursion, neodymium magnet, waterproof cone
<b>RATED POWER (2)</b>	15": 1000W AES, 4000W peak 12": 800W AES, 3200W peak
<b>SYSTEM AMPLIFIER</b>	iKON iK42
<b>SENSITIVITY (10)</b>	101dB
<b>MAXIMUM SPL(9)</b>	137dB peak
<b>NOMINAL IMPEDANCE</b>	15": 8 ohms, 12": 8 ohms
<b>DISPERSION</b>	Cardioid
<b>CONNECTOR</b>	2 x NL4
<b>PIN CONNECTIONS (INPUT)</b>	15": +1, -1; 12": +2, -2
<b>PIN CONNECTIONS (LINK)</b>	15": +1, -1; 12": +2, -2
<b>FITTINGS</b>	Two skids on base, with mating channels on top M20 top-mounted thread plate for pole mounting Two bar handles on each side, 16 x M10 mounting points 16 x M8 inserts for optional castors
<b>DIMENSIONS (INCL SKIDS)</b>	(W) 500mm x (H) 550mm x (D) 811mm (939mm incl castors) (W) 19.69in x (H) 21.67in x (D) 31.92in (36.96in incl castors)
<b>WEIGHT</b>	53kg (117lbs), 56kg (124 lbs) incl castors

## SXC118

SXCF118 – FLYING VARIANT  
ALSO AVAILABLE



<b>TYPE</b>	Compact, cardioid subwoofer
<b>FREQUENCY RESPONSE</b>	43Hz – 150Hz ±3dB, -10dB @ 34Hz
<b>DRIVERS</b>	18" (460mm)/4" (100mm) voice coil, long excursion, ferrite magnet, waterproof cone 14" (356mm)/3.5" (89mm) voice coil, long excursion, neodymium magnet, waterproof cone
<b>RATED POWER (2)</b>	18": 1000W AES, 4000W peak 14": 800W AES, 3200W peak
<b>SYSTEM AMPLIFIER</b>	iKON iK42
<b>SENSITIVITY</b>	104dB
<b>MAXIMUM SPL</b>	140dB peak
<b>NOMINAL IMPEDANCE</b>	18": 8 ohms, 14": 8 ohms
<b>DISPERSION</b>	Cardioid
<b>CONNECTOR</b>	2 x NL4
<b>FITTINGS</b>	Two skids on base, with mating channels on top M20 top-mounted thread plate for pole mounting Two bar handles on each side Four fittings for optional transit cover 16 x M8 inserts for optional castors
<b>DIMENSIONS (INCL SKIDS)</b>	(W) 635mm x (H) 603mm x (D) 824mm (952mm incl castors) (W) 25in x (H) 23.7in x (D) 32.4in (37.5in incl castors)
<b>WEIGHT</b>	69kg (152lbs), 73kg (161lbs) incl castors

## SX218



<b>TYPE</b>	Dual-driver, direct radiating subwoofer
<b>FREQUENCY RESPONSE (1)</b>	35Hz – 150Hz ±3dB, -10dB @ 30Hz
<b>DRIVER</b>	2 x 18" (460mm)/4" (100mm) voice coil, long excursion, ferrite magnet, waterproof cone
<b>SYSTEM AMPLIFIER</b>	iKON iK42
<b>SENSITIVITY (10)</b>	105dB
<b>MAXIMUM SPL(9)</b>	144dB peak
<b>NOMINAL IMPEDANCE</b>	2 x 8 Ohms
<b>CONNECTORS</b>	2 x N4
<b>FITTINGS</b>	Two skids on base, with mating channels on top 16 x M8 inserts for optional castors 24 x M10 mounting points 4 x bar handles, 2 on each side 4 x fittings for optional transit cover M20 pole mount insert
<b>DIMENSIONS (INCL SKIDS)</b>	(W) 1093mm x (H) 537mm x (D) 792mm (920mm including castors) (W) 43in x (H) 21.1in x (D) 31.2in (36.2in including castors)
<b>WEIGHT</b>	102kg (225lbs) with castors

## SXH218



<b>TYPE</b>	Hybrid® horn/reflex subwoofer
<b>FREQUENCY RESPONSE (1)</b>	32Hz – 150Hz ±3dB, -10dB @ 27Hz
<b>DRIVERS</b>	2 x 18" (460mm)/4.5" (115mm) voice coil, long excursion, neodymium magnet, waterproof
<b>RATED POWER (2)</b>	3000W AES, 12000W peak
<b>Recommended Amplifier</b>	iKON iK42
<b>SENSITIVITY (10)</b>	107dB
<b>MAXIMUM SPL(9)</b>	148dB peak (at 1m half space)
<b>NOMINAL IMPEDANCE</b>	4 Ohms
<b>DISPERSION (-6dB)</b>	Omnidirectional/or Cardioid (paired)
<b>ENCLOSURE</b>	Multi-laminate birch/poplar ply
<b>FINISH</b>	Textured Black Polyurea
<b>PROTECTIVE GRILLE</b>	Black perforated steel
<b>CONNECTORS</b>	2 x N4
<b>PIN CONNECTIONS</b>	Input: +/1-, refer to input panel for four-core cable link diagram
<b>FITTINGS</b>	Two skids on base, with mating channels on top Four rear-mounted 100mm (4in) castors 6 x bar handles, 3 on each side 4 x fittings for optional transit cover
<b>DIMENSIONS (INCL SKIDS)</b>	(W) 1112mm x (H) 609mm x (D) 1023mm (1151mm incl. castors) (W) 43.8in x (H) 24in x (D) 40.3in (45.3in incl. castors)
<b>WEIGHT</b>	120kg (264lbs), with castors 124kg (273lbs)

## SXP118



<b>TYPE</b>	Compact, direct radiating powered subwoofer with onboard DSP, networking & Dante
<b>FREQUENCY RESPONSE</b>	43Hz – 150Hz ±3dB, -10dB @ 30Hz
<b>DRIVER</b>	18" (460mm)/4" (100mm) voice coil, long excursion, ferrite magnet, waterproof cone
<b>INPUT SENSITIVITY</b>	-30dBu for 100dB SPL
<b>MAXIMUM SPL</b>	132dB continuous / 135dB peak
<b>DISPERSION</b>	Omnidirectional / or Cardioid (paired)
<b>AMPLIFIER TYPE</b>	2 channel switch-mode, class D, Bridged Tied
<b>PEAK OUTPUT POWER</b>	2000W total
<b>AC INPUT OPERATING RANGE</b>	85 – 265V ~ AC, 50 - 60Hz
<b>FITTINGS</b>	Two skids on base, with mating channels on top 16 x M8 inserts for optional castors M20 top-mounted thread plate for pole mounting 16 x M10 mounting points 2x Bar handles, 1 on each side 4x fittings for optional transit cover Optional weather protection cowl
<b>ACCESSORIES</b>	Transit Cover
<b>DIMENSIONS (inc. castors)</b>	(W) 600mm x (H) 507mm x (D) 632mm (760mm) (W) 23.62in x (H) 20in x (D) 24.86in (29.90in)
<b>WEIGHT</b>	50kg (110lbs) excluding Transit cover

## SXP218



<b>TYPE</b>	Compact, direct radiating powered subwoofer with onboard DSP, networking & Dante
<b>FREQUENCY RESPONSE</b>	35Hz – 150Hz ±3dB, -10dB @ 30Hz
<b>DRIVER</b>	18" (460mm)/4" (100mm) voice coil, long excursion, ferrite magnet, waterproof cone
<b>INPUT SENSITIVITY</b>	-30dBu for 100dB SPL
<b>MAXIMUM SPL</b>	140dB continuous / 143dB peak
<b>DISPERSION</b>	Omnidirectional / or Cardioid (paired)
<b>AMPLIFIER TYPE</b>	Two 2 channel switch-mode, class D, Bridged Tied Load
<b>PEAK OUTPUT POWER</b>	4000W
<b>AC INPUT OPERATING RANGE</b>	85 – 265V ~ AC, 50 - 60Hz
<b>FITTINGS</b>	Two skids on base, with mating channels on top 16 x M8 inserts for optional castors 24 x M10 mounting points 4x Bar handles, 2 on each side 4x fittings for optional transit cover Optional weather protection cowl M20 pole mount insert
<b>ACCESSORIES</b>	Transit Cover
<b>DIMENSIONS (inc. castors)</b>	(W) 1085mm x (H) 537mm x (D) 792mm (920mm) (W) 42.72in x (H) 20.87in x (D) 31.16in (36.20in)
<b>WEIGHT</b>	105kg (231lbs) excluding Transit cover



## XE Series

Musicians benefit from an onstage environment where they sound great. Hearing their individual performance, as well as the overall sound of the other musicians with clarity, dynamism and presence is essential to a confident performance that unites the band onstage. This is the realm of the stage monitor — the vital bridge between the artist and the audience.

Martin Audio brings engineering innovation to stage monitoring with the XE Series — setting a new reference in sonic excellence and defined coverage. Designed in consultation with leading monitor engineers and combining sleek, low-profile enclosures with unique CDD™ Coaxial Differential Dispersion technology, the XE300 and XE500 deliver perfect monitor sound with a defined coverage pattern that allows the artist freedom of movement, while reducing overlap with adjacent monitors.

The patented Coaxial Differential Dispersion driver combined with a patent pending contour moulded static waveguide allows the artist to stand directly over the monitor or further back, without significant changes in SPL or tonal balance. It produces the optimal coverage pattern over a listening plane at head-height and helps to contain the sound within that region.

Designed as a complete system, the state of the art iKON 4 channel Class D amplifier maximises the capability of the monitor while ensuring both engineer and artist can be confident they will experience the same high level of consistent performance from an XE monitor anywhere in the world.



## XE500



TYPE	Two-way, bi-amp, Coaxial Differential Dispersion stage monitor
FREQUENCY RESPONSE (3)	62Hz-18kHz $\pm$ 3dB -10dB @ 45Hz
DRIVERS	LF: 1.5" (38mm)/3.5" (89mm) voice coil, dual-gap neodymium motor system HF: 1.4" (35mm) exit/3" (75mm) voice coil, titanium dome compression driver
SYSTEM AMPLIFIER	iKON® iK42
MAXIMUM SPL (9)	143dB peak
NOMINAL IMPEDANCE	LF: 4 ohms, HF: 8ohms
DISPERSION (-6dB)	60-30° horizontal, 70° vertical
CONNECTORS	4 x NL4 type
FITTINGS	2 x bar handles Protective rubber feet on base and sides Built-in risers 4 x M8 inserts
DIMENSIONS INCL FEET	(W) 641mm x (H) 367mm x (D) 583mm (W) 25.2ins x (H) 14.4ins x (D) 22.9ins
WEIGHT	29kg (63.9lbs)

## XE300



TYPE	Two-way, bi-amp/passive, Coaxial Differential Dispersion stage monitor
FREQUENCY RESPONSE (3)	67Hz-18kHz $\pm$ 3dB -10dB @ 55Hz
DRIVERS	LF: 1.2" (30mm)/3" (75mm) voice coil, dual-gap neodymium motor system HF: 1.4" (35mm) exit/3" (75mm) voice coil, titanium dome compression driver
SYSTEM AMPLIFIER	iKON® iK42
MAXIMUM SPL (9)	Bi-amp: 140dB peak. Passive: 139dB peak
NOMINAL IMPEDANCE	LF/FR: 6 ohms, HF: 8ohms
DISPERSION (-6dB)	60-30° horizontal, 90° vertical
CONNECTORS	4 x NL4 type
FITTINGS	2 x pocket handles Protective rubber feet on base and sides Built-in risers 4 x M8 inserts
DIMENSION INCL FEET	(W) 556mm x (H) 293mm x (D) 470mm (W) 21.9ins x (H) 11.5ins x (D) 18.5ins
WEIGHT	19kg (41.9lbs)

## iK42



TYPE	Four-channel Class D amplifier
TOTAL OUTPUT POWER	20,000 Watts RMS, all channels driven
DIGITAL SIGNAL PROCESSING	96kHz DSP on all inputs and outputs
COOLING	Dual vari-speed fans, front-to-back airflow
MAXIMUM AMBIENT TEMPERATURE	40°C (104°F)
ANALOGUE I/O/LINK (4 CHANNELS)	4 x female, 4 x male Neutrik™ XLR
ANALOGUE INPUT IMPEDANCE	20k $\Omega$ balanced to ground
MAXIMUM ANALOGUE INPUT LEVEL	+20dBu
NOMINAL SYSTEM GAIN	32dB
AES3 I/O/LINK (2 CHANNELS)	1 x female, 1 x male Neutrik™ XLR, balanced
DANTE™ (4 CHANNELS)	2 x shielded RJ45, primary and secondary
AMPLIFIER OUTPUTS	4 x Neutrik Speakon™ NL4
TOPOLOGY	Ethernet
CONTROL APPLICATION	Martin Audio VU-NET™
TYPE	High performance Series Resonant
AC INPUT OPERATING RANGE	85 – 240V ~ AC, 47 - 63Hz
MAINS INRUSH CURRENT	6A at 15V, 12A at 230V (max for <10ms)
MAINS CONNECTOR	Neutrik 32A Powercon™
DIMENSIONS	(W) 483 x (H) 2U/89mm x (D) 357mm (W) 19in x (H) 2U/3.5in x (D) 14.1in incl handles and optional rear support
WEIGHT	12.5kg (27.5lbs)



## LE Series

The stage monitor plays a key role in creating an onstage environment that connects performers to the audience. Martin Audio's first LE monitor led the way to become the industry standard in the early 1970s, and LE monitors have continued to make their presence felt in the decades since. Complementing Martin Audio's state-of-the-art, high-performance XE Series monitors, the latest LE Series now brings engineering innovation to everyday stage monitoring — delivering exceptional performance and controlled coverage at a price point not previously possible for a truly professional monitor.

Both the LE100 and the LE200 are designed for a wide range of users and applications — from up-and-coming bands and regional rental houses, to corporate AV events, HoW and fixed installations.

With extremely compact enclosures and unique CDD™ Coaxial Differential Dispersion technology, the LE Series monitors deliver cut-through sound with a coverage pattern that allows performers greater freedom of movement compared to conventional monitors. Instead of the typical 'hot-spot', they produce a near-rectangular coverage pattern over a listening plane at head-height — with a wide horizontal coverage close to the monitor that reduces gradually as distance increases to maintain consistent SPL and tonal balance.

Professional and affordable, the latest LE Series puts great sound, optimised coverage and the very latest in innovative monitor technology literally at your feet.



## LE200

TYPE	Two-way, bi-amp/passive Coaxial Differential Dispersion stage monitor
FREQUENCY RESPONSE (3)	60Hz-18kHz $\pm$ 3dB -10dB @ 50Hz
DRIVERS	LF: 15" (380mm)/3" (75mm) voice coil, long excursion, shared ferrite motor system with HF HF: 1.4" (32mm) exit/3" (75mm) voice coil, titanium dome compression driver
RATED POWER (2)	400W AES, 1600W peak
RECOMMENDED AMPLIFIER	MA3.0, MA5.00
SENSITIVITY (3)	LF: 100dB, HF: 103dB Passive: 100dB
MAXIMUM SPL (9)	133dB peak
NOMINAL IMPEDANCE	LF/FR: 8 ohms, HF: 8 ohms
DISPERSION (-6dB)	100°-60° horizontal, 60° vertical
CONNECTORS	4 x NL4 type
FITTINGS	2 x bar handles Protective rubber feet on base and sides 4 x M8 inserts
DIMENSIONS INCL FEET	(W) 616mm x (H) 367mm x (D) 562mm (W) 24.2ins x (H) 14.4ins x (D) 22.1ins
WEIGHT	26kg (57.3lbs)



## LE100

TYPE	Two-way passive, Coaxial Differential Dispersion stage monitor
FREQUENCY RESPONSE (3)	78Hz-20kHz $\pm$ 3dB -10dB @ 58Hz
DRIVERS	LF: 12" (300mm)/2.5" (63.5mm) voice coil, long excursion, shared ferrite motor system with HF HF: 1" (25mm) exit/1.7" (44mm) voice coil, polyimide dome compression driver
RATED POWER (2)	300W AES, 1200W peak
RECOMMENDED AMPLIFIER	MA2.0, MA3.0, MA5.00
SENSITIVITY (3)	97dB
MAXIMUM SPL (9)	129dB peak
NOMINAL IMPEDANCE	8 ohms
DISPERSION (-6dB)	110°-60° horizontal, 60° vertical
CONNECTORS	5 x NL4 type
FITTINGS	2 x pocket handles Protective rubber feet on base and sides 4 x M8 inserts Pole-mount socket
DIMENSIONS INCL FEET	(W) 496mm x (H) 305mm x (D) 472mm (W) 19.5ins x (H) 12.0ins x (D) 18.6ins
WEIGHT	18kg (39.7lbs)



## CDD-LIVE!

Until now, most self-powered portable loudspeakers have been underpowered, light-duty systems or very high-end systems out of reach of many users. Now, with the multi-purpose CDD-LIVE! Series, Martin Audio brings everything rental companies, systems integrators and musicians require from a self-powered loudspeaker into sharp focus.

Comprising three full-range models and when complimented by SXP subwoofers, CDD-LIVE! covers practically all professional stand-alone and distributed applications — from sound reinforcement and monitoring for live bands, DJ's and corporate events, to installations in dance clubs, ballrooms, theatres and performing arts centres.

Combining the 'point-source' benefits of coaxial designs with the consistent coverage of Differential Dispersion technology, CDD-LIVE! full-range systems project sound evenly front-to-back while exhibiting wide horizontal coverage close to the speaker — delivering ultimate fidelity and impact to all corners of the audience.



Onboard Class D amplification, DSP and Dante™ Digital Audio networking assure simplicity of stage set-up and efficient installation, while tour-grade enclosures and comprehensive mounting options — including pole mount, wall brackets, yokes and rigging inserts — provide maximum flexibility in deployment.

With sonic consistency across the range, a rectangular coverage footprint and a multitude of deployment options, CDD-LIVE! is truly versatile — the professional self-powered solution that means business.

CDD-LIVE! 'The Sound of Things to Come'

## CDD-LIVE 8

<b>TYPE</b>	Ultra-compact, Coaxial Differential Dispersion powered two-way system with onboard DSP, networking & Dante
<b>FREQUENCY RESPONSE</b>	70Hz – 20kHz ±3dB, -10dB @ 50Hz
<b>DRIVER</b>	LF: 8" (200mm)/2" (50mm) voice coil, long excursion, shared ferrite motor system with HF HF: 1" (25mm) exit/1.4" (38mm) voice coil, polyimide dome compression driver
<b>INPUT SENSITIVITY</b>	-26dBu for 100dB SPL
<b>MAXIMUM SPL</b>	117dB continuous / 123dB peak
<b>DISPERSION</b>	110° - 80° horizontal, 60° vertical (user-rotatable)
<b>AMPLIFIER TYPE</b>	2 channel switch-mode, class D
<b>PEAK OUTPUT POWER</b>	1000W LF, 300W HF
<b>AC INPUT OPERATING RANGE</b>	85 – 265V ~ AC, 50 - 60Hz
<b>FITTINGS</b>	Top hat for pole mounting 15 x M8 mounting points Single pocket handle Optional weather protection cowl
<b>ACCESSORIES</b>	Transit Cover. Optional wall, yoke and universal brackets
<b>DIMENSIONS</b>	(W) 258mm x (H) 428mm x (D) 254mm (W) 10.16in x (H) 16.85in x (D) 10.00in
<b>WEIGHT</b>	14kg (30.8lbs) excluding Transit cover



## CDD-LIVE 15

<b>TYPE</b>	Ultra-compact, Coaxial Differential Dispersion powered two-way system with onboard DSP, networking & Dante
<b>FREQUENCY RESPONSE</b>	55Hz – 20kHz ±3dB, -10dB @ 45Hz
<b>DRIVER</b>	LF: 15" (380mm)/3" (75mm) voice coil, long excursion, shared ferrite motor system with HF HF: 1.4" (36mm) exit/3" (75mm) voice coil, titanium dome compression driver
<b>INPUT SENSITIVITY</b>	-30dBu for 100dB SPL
<b>MAXIMUM SPL</b>	126dB continuous / 132dB peak
<b>DISPERSION</b>	100° - 60° horizontal, 60° vertical (user-rotatable)
<b>AMPLIFIER TYPE</b>	2 channel switch-mode, class D, Bridged Tied Load + 1 channel switch-mode, class D
<b>PEAK OUTPUT POWER</b>	2000W LF, 500W HF
<b>AC INPUT OPERATING RANGE</b>	85 – 265V ~ AC, 50 - 60Hz
<b>FITTINGS</b>	Top hat for pole mounting 15 x M8 mounting points Two side pocket handles Optional weather protection cowl
<b>ACCESSORIES</b>	Transit Cover. Optional wall, yoke and universal brackets
<b>DIMENSIONS</b>	(W) 427mm x (H) 696mm x (D) 422mm (W) 16.81in x (H) x 27.42in (D) 16.61in
<b>WEIGHT</b>	37kg (81.4lbs) excluding Transit cover



## CDD-LIVE 12

<b>TYPE</b>	Ultra-compact, Coaxial Differential Dispersion powered two-way system with onboard DSP, networking & Dante
<b>FREQUENCY RESPONSE</b>	62Hz – 20kHz ±3dB, -10dB @ 50Hz
<b>DRIVER</b>	LF: 12" (300mm)/2.5" (63.5mm) voice coil, long excursion, shared ferrite motor system with HF HF: 1" (25mm) exit/1.7" (44mm) voice coil, polyimide dome compression driver
<b>INPUT SENSITIVITY</b>	-30dBu for 100dB SPL
<b>MAXIMUM SPL</b>	122dB continuous / 128dB peak
<b>DISPERSION</b>	110° - 60° horizontal, 60° vertical (user-rotatable)
<b>AMPLIFIER TYPE</b>	2 channel switch-mode, class D, Bridged Tied Load + 1 channel switch-mode, class D
<b>PEAK OUTPUT POWER</b>	2000W LF, 500W HF
<b>AC INPUT OPERATING RANGE</b>	85 – 265V ~ AC, 50 - 60Hz
<b>FITTINGS</b>	Top hat for pole mounting 15 x M8 mounting points Two side pocket handles Optional weather protection cowl
<b>ACCESSORIES</b>	Transit Cover. Optional wall, yoke and universal brackets
<b>DIMENSIONS</b>	(W) 359mm x (H) 580mm x (D) 373mm (W) 14.13in x (H) 22.83in x (D) 14.69in
<b>WEIGHT</b>	28kg (61.6lbs) excluding Transit cover



## BlacklineX Powered

The new portable BlacklineX Powered Series integrates all of our engineering expertise into easy-to-use, quick-to-deploy, high-powered loudspeakers that bring professional quality sound, top-flight performance and road-worthy durability into the hands of hard-working industry professionals — from musicians, music bars and mobile DJ's, to corporate AV, House of Worship installations and more.

With optional Bluetooth control, streaming and a built-in three channel mixer, BlacklineX Powered puts Martin Audio signature stadium sound at your fingertips.

Comprising the XP12 and XP15 two-way systems and XP118 subwoofer, BlacklineX Powered incorporates the best-in-class performance, durability and reliability associated with Martin Audio professional systems in a range of affordable, portable self-powered loudspeakers.



## XP12

TYPE	Compact self-powered two-way system
FREQUENCY RESPONSE	62Hz – 20kHz ± 3dB -10dB @ 50Hz
DRIVERS	LF: 12" (300mm)/2.5" (63.5mm) voice coil, ferrite motor system HF: 1" (25mm) exit/1.7" (44mm) voice coil, polyimide dome compression driver
MAXIMUM SPL	122dB continuous, 128dB peak
DISPERSION	80° H x 50° V (user-rotatable)
CROSSOVER	2.3kHz active, 24dB/octave
AMPLIFIER TYPE	2 channel switch-mode, class D
PEAK OUTPUT POWER	1300W total 1000W LF, 300W HF
AC INPUT OPERATING RANGE	Switch-mode, fixed frequency with PFC 100-240V ~ AC, 50 - 60Hz
FITTINGS	17 x M8 inserts, pole-mount socket, 2 x pocket handles
DIMENSIONS	(W) 358mm x (H) 574mm x (D) 318mm (W) 14.1in x (H) 22.6in x (D) 12.5in
WEIGHT	18kg (40lbs)



## XP118

TYPE	Compact, direct radiating powered subwoofer
FREQUENCY RESPONSE	42Hz – 150Hz ± 3dB -10dB @ 38Hz
DRIVER	18" (460mm)/4" (100mm) voice coil, long excursion, ferrite magnet
MAXIMUM SPL	131dB continuous / 137dB peak (half space)
DISPERSION	Omnidirectional
CROSSOVER	100Hz, active
AMPLIFIER TYPE	Class D, Bridged Tied
PEAK OUTPUT POWER	2000W total
AC INPUT OPERATING RANGE	100 – 240V ~ AC, 50 - 60Hz
FITTINGS	16 x M10 inserts, pole-mount socket 2 x bar handles, provision for castors
DIMENSIONS	(W) 662mm x (H) 536mm x (D) 640mm (W) 26.1in x (H) 21.1in x (D) 25.2in
WEIGHT	44kg (97lbs)



## XP15

TYPE	High output, self-powered two-way system
FREQUENCY RESPONSE	55Hz – 20kHz ± 3dB -10dB @ 45Hz
DRIVERS	LF: 15" (380mm)/3" (75mm) voice coil ferrite motor system HF: 1" (25mm) exit/1.7" (44mm) voice coil, polyimide dome compression driver
MAXIMUM SPL	125dB continuous / 131 dB peak
DISPERSION	80° H x 50° V (user-rotatable)
CROSSOVER	2kHz active, 24dB/octave
AMPLIFIER TYPE	2 channel switch-mode, Class D
PEAK OUTPUT POWER	1300W total 1000W LF, 300W HF
AC INPUT OPERATING RANGE	100-240V ~ AC, 50 - 60Hz
FITTINGS	13 x M8 inserts, pole-mount socket, 2 x pocket handles
DIMENSIONS	(W) 427mm x (H) 690mm x (D) 407mm (W) 16.8in x (H) 27.2 x (D) 16.0in
WEIGHT	26kg (57lbs)





## TH Series

The TH Series consists of two, very high performance, all-horn, three-way systems. Each is configured in a single wide-bandwidth package with extended frequency response and very high output capability.

Ideally suited to larger club applications and large scale installs, the TH Series also aesthetically complements the CDD, BlacklineX and SX subwoofer ranges.

Horn-loading the bass and midrange sections as well as the high-frequency section maximises the efficiency of all bands, resulting in exceptional impact and output from a single enclosure. Bi-amp operation, with an internal passive network for the mid/high crossover, ensures the most effective use of available amplifier power.

Sonically, TH Series systems deliver the Martin Audio signature sound of warmth, clarity and smooth response at high levels with ease.

THH is a horizontally formatted system while THV is a vertically formatted system.



## THV

<b>TYPE</b>	Three-way bi-amp trapezoid Hybrid® fully horn loaded
<b>FREQUENCY RESPONSE (5)</b>	50Hz-18kHz ± 3dB
<b>DRIVERS</b>	15" (380mm)/4" (100mm) coil bass driver 10" (250mm)/2.5" (63.5mm) coil mid driver 1" (25mm) exit HF compression driver
<b>RATED POWER (2)</b>	LF: 750W AES, 3000W peak MF + HF: 300W AES, 1200W peak
<b>RECOMMENDED AMPLIFIER</b>	iK42 / VIA5002/5004
<b>SENSITIVITY (6)</b>	LF: 104dB, MF + HF: 104dB
<b>MAXIMUM SPL (9)</b>	133dB continuous, 139dB peak
<b>NOMINAL IMPEDANCE</b>	LF: 8 ohms, MF + HF: 8 ohms
<b>DISPERSION (-6dB)</b>	70° horizontal, 40° vertical
<b>CROSSOVER</b>	200Hz active, 2kHz passive
<b>ENCLOSURE</b>	250 litre, multi-laminate birch ply
<b>FINISH</b>	Textured black paint
<b>PROTECTIVE GRILLE</b>	Black perforated steel
<b>CONNECTORS</b>	2 x Neutrik NL4
<b>PIN CONNECTIONS</b>	LF +, -: 1 +, 1-, (MF + HF) +, -: 2 +, 2-
<b>FITTINGS</b>	12 x M10 inserts 4 x 4" (100mm) castors, 4 x pocket handles
<b>DIMENSIONS (inc wheels)</b>	(W) 558mm x (H) 1067mm x (D) 780mm (908mm) (W) 22ins x (H) 42ins x (D) 30.7ins (35.7ins)
<b>WEIGHT</b>	77.5kg (170.5lbs)



## THH

<b>TYPE</b>	Three-way bi-amp trapezoid Hybrid® fully horn loaded
<b>FREQUENCY RESPONSE (5)</b>	50Hz-18kHz ± 3dB
<b>DRIVERS</b>	15" (380mm)/4" (100mm) coil bass driver 10" (250mm)/2.5" (63.5mm) coil mid driver 1" (25mm) exit HF compression driver
<b>RATED POWER (2)</b>	LF: 750W AES, 3000W peak MF + HF: 300W AES, 1200W peak
<b>RECOMMENDED AMPLIFIER</b>	iK42 / VIA5002/5004
<b>SENSITIVITY (6)</b>	LF: 104dB, MF + HF: 104dB
<b>MAXIMUM SPL (9)</b>	133dB continuous, 139dB peak
<b>NOMINAL IMPEDANCE</b>	LF: 8 ohms, MF + HF: 8 ohms
<b>DISPERSION (-6dB)</b>	70° horizontal, 40° vertical
<b>CROSSOVER</b>	200Hz active, 2kHz passive
<b>ENCLOSURE</b>	250 litre, multi-laminate birch ply
<b>FINISH</b>	Textured black paint
<b>PROTECTIVE GRILLE</b>	Black perforated steel
<b>CONNECTORS</b>	2 x Neutrik NL4
<b>PIN CONNECTIONS</b>	LF +, -: 1 +, 1-, (MF + HF) +, -: 2 +, 2-
<b>FITTINGS</b>	12 x M10 inserts, 4 x 4" (100mm) castors, 4 x pocket handles
<b>DIMENSIONS (inc wheels)</b>	(W) 1067mm x (H) 558mm x (D) 780mm (908mm) (W) 42ins x (H) 22ins x (D) 30.7ins (35.7ins)
<b>WEIGHT</b>	77.5kg (170.5lbs)



## XD Series

The XD Series loudspeakers are the perfect solution for high-power applications where flexibility, ease of installation and speed of deployment are important factors. The versatile, multi-angle enclosures and rotatable horns facilitate either horizontal or vertical orientation, and comprehensive brackets support the full variety of mounting options. Integral M8 inserts increase the options even further. When configured horizontally, the XD15 and XD12 are also ideal as compact, high-output stage monitors.



The XD15 and XD12 LF drivers both feature neodymium motor systems which combine high sensitivity with low weight and advanced cooling to reduce power compression to negligible levels, and the HF compression drivers feature ultra-high flux neodymium magnet systems for maximum efficiency. The tour-grade plywood enclosures are coated in hard-wearing polyurethane and have pre-curved Declon® backed perforated steel grilles.

The XD Series loudspeakers deliver best-in-class performance, including higher output levels and more extended frequency range than is normally associated with similarly-sized systems.

XD Series – the new benchmark for the compact two-way format.

## XD15

<b>TYPE</b>	Very high-output, passive/bi-amp, two-way system
<b>FREQUENCY RESPONSE (5)</b>	55Hz-18kHz $\pm$ 3dB, -10dB @ 45Hz
<b>DRIVERS</b>	15" (380mm)/4" (100mm) voice coil, long excursion, neodymium magnet LF driver 1.4" (35mm) exit/3" (75mm) voice coil, titanium dome, neodymium magnet HF compression driver
<b>RATED POWER (2)</b>	FR/LF: 600W AES, 2400W peak HF: 80W AES, 320W peak
<b>SENSITIVITY (6)</b>	FR: 99dB LF: 100dB HF: 108dB
<b>MAXIMUM SPL (9)</b>	FR: 126dB continuous, 132dB peak LF: 127dB continuous, 133dB peak HF: 127dB continuous, 133dB peak
<b>NOMINAL IMPEDANCE</b>	FR/LF: 8 ohms, HF: 16 ohms
<b>DISPERSION (-6dB)</b>	80° horizontal, 50° vertical user rotatable
<b>CONNECTORS</b>	2 x Neutrik® NL4
<b>FITTINGS</b>	17 x M8 threaded inserts 1 x Pole mount socket 2 x Pocket handles
<b>DIMENSIONS</b>	(W) 429mm x (H) 690mm x (D) 414mm (W) 16.9ins x (H) 27.2ins x (D) 16.3ins
<b>WEIGHT</b>	32kg (70.5lbs)



## XD12

<b>TYPE</b>	Compact, high output, passive/bi-amp, two-way system
<b>FREQUENCY RESPONSE (5)</b>	65Hz-20kHz $\pm$ 3dB, -10dB @ 55Hz
<b>DRIVERS</b>	12" (300mm)/3" (75mm) voice coil, long excursion, neodymium magnet LF driver 1" (25mm) exit/1.7" (44mm) voice coil, titanium dome, neodymium magnet HF compression driver
<b>RATED POWER (2)</b>	FR/LF: 400W AES, 1600W peak HF: 50W AES, 200W peak
<b>SENSITIVITY (6)</b>	FR: 98dB LF: 99dB HF: 108dB
<b>MAXIMUM SPL (9)</b>	FR: 124dB continuous, 130dB peak LF: 125dB continuous, 131dB peak HF: 125dB continuous, 131dB peak
<b>NOMINAL IMPEDANCE</b>	FR/LF: 8 ohms, HF: 16 ohms
<b>DISPERSION (-6dB)</b>	80° horizontal, 50° vertical user rotatable
<b>CONNECTORS</b>	2 x Neutrik® NL4
<b>FITTINGS</b>	21 x M8 threaded inserts 1 x Pole mount socket 1 x Pocket handle
<b>DIMENSIONS</b>	(W) 360mm x (H) 571mm x (D) 341mm (W) 14.2ins x (H) 22.5ins x (D) 13.4ins
<b>WEIGHT</b>	19.5kg (43lbs)



The Dorchester, UK

# CDD Series

Martin Audio brings engineering innovation to installed sound with the all-new CDD™ Series — combining distinctive curved enclosures with unique Coaxial Differential Dispersion™ technology to deliver class-leading performance, fidelity and coverage consistency to venues that demand the ultimate in cutting-edge technology and style.

Whether it's a bar, an AV installation, a church or a prestige nightclub — the CDD Series has it covered. CDD is the one-stop solution; six two-way full-range coaxial systems — from the micro CDD5 to the powerful CDD15, complemented by high-performance subwoofers — cover practically all install applications.

The CDD Series has the audience covered too. Coaxial Differential Dispersion technology delivers more consistent

audience coverage than systems with X° x Y° horns — projecting more output to the rear of the audience to distribute sound evenly front-to-back, while having wide horizontal coverage close-up.

Visually-appealing enclosure design is a signature of the CDD Series. The full-range enclosures can be used in either horizontal or vertical orientation, with rotation of the coaxial driver easily accomplished by removing the screw-free, protective grille. The curved shape of each full-range enclosure allows it to be discreetly mounted close to a wall and threaded inserts are provided for eyebolt suspension of most models.

The CDD Series — the shape of things to come.

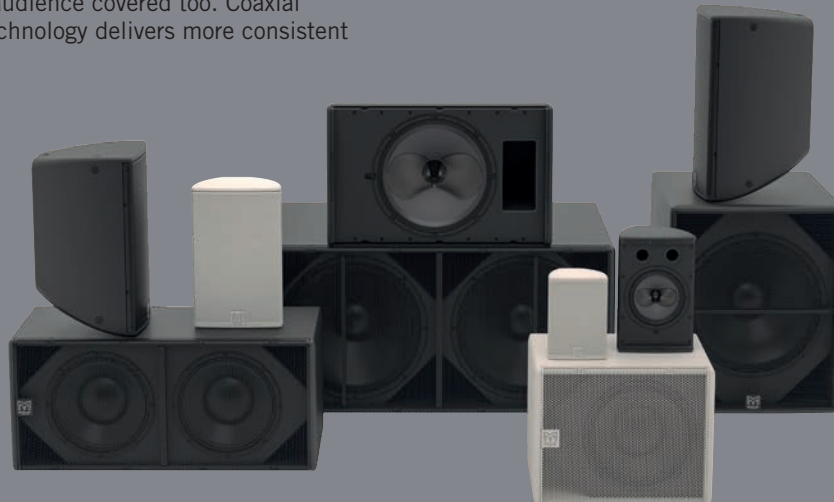

## CDD5



TYPE	Ultra-compact, Coaxial Differential Dispersion passive two-way system
FREQUENCY RESPONSE (5)	100Hz-20kHz $\pm$ 3dB, -10dB @ 70Hz
COAXIAL DRIVER	LF: 5.25" (130mm)/1.25" (32mm) voice coil, long excursion, ferrite motor system HF: 0.75" (19mm) voice coil, fabric dome with neodymium motor system
RATED POWER (2)	100W AES, 400W peak
SENSITIVITY (8)	90dB
MAXIMUM SPL (9)	110dB continuous, 116dB peak
NOMINAL IMPEDANCE	8 ohms
DISPERSION (-6dB)	120°-90° horizontal, 80° vertical (user-rotatable)
CONNECTORS	Low profile 13A push-lock
FITTINGS	6 x M5 inserts for wall/ceiling brackets
DIMENSIONS	(W) 160mm x (H) 230mm x (D) 149mm (W) 6.3ins x (H) 9.1 ins x (D) 5.9 ins
WEIGHT	3kg (6.6lbs)

CDD5 is supplied with wall mount tilt/pan bracket

## CDD6



TYPE	Ultra-compact, Coaxial Differential Dispersion passive two-way system
FREQUENCY RESPONSE (5)	80Hz-20kHz $\pm$ 3dB, -10dB @ 70Hz
COAXIAL DRIVER	LF: 6.5" (165mm)/1.5" (38mm) voice coil, long excursion, ferrite motor system HF: 1" (25mm) voice coil, fabric dome with neodymium motor system
RATED POWER (2)	150W AES, 600W peak
SENSITIVITY (8)	91dB
MAXIMUM SPL (9)	113dB continuous, 119dB peak
NOMINAL IMPEDANCE	8 ohms
DISPERSION (-6dB)	110°-80° horizontal, 80° vertical (user-rotatable)
CONNECTORS	Low profile 13A push-lock
FITTINGS	4 x M6 inserts for wall/ceiling brackets
DIMENSIONS	(W) 210mm x (H) 325mm x (D) 210mm (W) 8.3ins x (H) 12.8ins x (D) 8.3ins
WEIGHT	5.5kg (12.1lbs)

## CDD8



TYPE	Ultra-compact, Coaxial Differential Dispersion passive two-way system
FREQUENCY RESPONSE (5)	70Hz-20kHz $\pm$ 3dB, -10dB @ 55Hz
COAXIAL DRIVER	LF: 8" (200mm)/2" (50mm) voice coil, long excursion, shared ferrite motor system with HF HF: 1" (25mm) exit/1.4" (38mm) voice coil, polyimide dome compression driver
RATED POWER (2)	200W AES, 800W peak
SENSITIVITY (8)	94dB
MAXIMUM SPL (9)	117dB continuous, 123dB peak
NOMINAL IMPEDANCE	8 ohms
DISPERSION (-6dB)	110°-80° horizontal, 60° vertical (user-rotatable)
CONNECTORS	Low profile 13A push-lock
FITTINGS	6 x M6 inserts for wall/ceiling brackets
DIMENSIONS	(W) 256mm x (H) 410mm x (D) 252mm (W) 10.1ins x (H) 16.1ins x (D) 9.9ins
WEIGHT	9.5kg (21lbs)

## CDD8-TX



TYPE	Ultra-compact, Coaxial Differential Dispersion passive two-way system
FREQUENCY RESPONSE (5)	70Hz-20kHz $\pm$ 3dB, -10dB @ 55Hz
COAXIAL DRIVER	LF: 8" (200mm)/2" (50mm) voice coil, long excursion, shared ferrite motor system with HF HF: 1" (25mm) exit/1.4" (38mm) voice coil, polyimide dome compression driver
RATED POWER (2)	200W AES, 800W peak
TRANSFORMER SETTINGS	100V/70V line: 120W, 60W, 30W, 15W
SENSITIVITY (8)	94dB
MAXIMUM SPL (9)	117dB continuous, 123dB peak
NOMINAL IMPEDANCE	8 ohms
DISPERSION (-6dB)	110°-80° horizontal, 60° vertical (user-rotatable)
CONNECTORS	Low profile 13A push-lock
FITTINGS	6 x M6 inserts for wall/ceiling brackets
DIMENSIONS	(W) 256mm x (H) 410mm x (D) 252mm (W) 10.1ins x (H) 16.1ins x (D) 9.9ins
WEIGHT	11.1kg (24.53lbs)

## CDD10



<b>TYPE</b>	Compact, Coaxial Differential Dispersion passive two-way system
<b>FREQUENCY RESPONSE (2)</b>	65Hz-20kHz $\pm$ 3dB, -10dB @ 55Hz
<b>COAXIAL DRIVER</b>	LF: 10" (250mm)/2.5" (63.5mm) voice coil, long excursion, shared ferrite motor system with HF HF: 1" (25mm) exit/1.4" (38mm) voice coil, polyimide dome compression driver
<b>RATED POWER (2)</b>	250W AES, 1000W peak
<b>SENSITIVITY (8)</b>	96dB
<b>MAXIMUM SPL (9)</b>	120dB continuous, 126dB peak
<b>NOMINAL IMPEDANCE</b>	8 ohms
<b>DISPERSION (-6dB)</b>	110°-75° horizontal, 60° vertical (user-rotatable)
<b>CONNECTORS</b>	Low profile 20A push-lock
<b>FITTINGS</b>	6 x M8 inserts for wall/ceiling brackets, 10 x M8 fly points
<b>DIMENSIONS</b>	(W) 323mm x (H) 513mm x (D) 310mm (W) 12.7ins x (H) 20.2ins x (D) 12.2ins
<b>WEIGHT</b>	15.3kg (33.7lbs)

## CDD10-TX



<b>TYPE</b>	Compact, Coaxial Differential Dispersion passive two-way system
<b>FREQUENCY RESPONSE (2)</b>	65Hz-20kHz $\pm$ 3dB, -10dB @ 55Hz
<b>COAXIAL DRIVER</b>	LF: 10" (250mm)/2.5" (63.5mm) voice coil, long excursion, shared ferrite motor system with HF HF: 1" (25mm) exit/1.4" (38mm) voice coil, polyimide dome compression driver
<b>RATED POWER (2)</b>	250W AES, 1000W peak
<b>TRANSFORMER SETTINGS</b>	100V/70V line: 120W, 60W, 30W, 15W
<b>SENSITIVITY (8)</b>	96dB
<b>MAXIMUM SPL (9)</b>	120dB continuous, 126dB peak
<b>NOMINAL IMPEDANCE</b>	8 ohms
<b>DISPERSION (-6dB)</b>	110°-75° horizontal, 60° vertical (user-rotatable)
<b>CONNECTORS</b>	Low profile 20A push-lock
<b>FITTINGS</b>	6 x M8 inserts for wall/ceiling brackets, 10 x M8 fly points
<b>DIMENSIONS</b>	(W) 323mm x (H) 513mm x (D) 310mm (W) 12.7ins x (H) 20.2ins x (D) 12.2ins
<b>WEIGHT</b>	16.9kg (37.23lbs)

## CDD12



<b>TYPE</b>	Compact, high-output, Coaxial Differential Dispersion passive two-way system
<b>FREQUENCY RESPONSE (5)</b>	62Hz-20kHz $\pm$ 3dB, -10dB @ 50Hz
<b>COAXIAL DRIVER</b>	LF: 12" (300mm)/2.5" (63.5mm) voice coil, long excursion, shared ferrite motor system with HF HF: 1" (25mm) exit/1.7" (44mm) voice coil, polyimide dome compression driver
<b>RATED POWER (2)</b>	300W AES, 1200W peak
<b>SENSITIVITY (8)</b>	97dB
<b>MAXIMUM SPL (9)</b>	122dB continuous, 128dB peak
<b>NOMINAL IMPEDANCE</b>	8 ohms
<b>DISPERSION (-6dB)</b>	110°-60° horizontal, 60° vertical (user-rotatable)
<b>CONNECTORS</b>	Low profile 20A push-lock
<b>FITTINGS</b>	6 x M8 inserts for wall/ceiling brackets, 10 x M8 fly points
<b>DIMENSIONS</b>	(W) 360mm x (H) 560mm x (D) 350mm (W) 14.2ins x (H) 22.05ins x (D) 13.8ins
<b>WEIGHT</b>	19kg (41.89lbs)

## CDD15



<b>TYPE</b>	High-output, Coaxial Differential Dispersion passive two-way system
<b>FREQUENCY RESPONSE (5)</b>	55Hz-18kHz $\pm$ 3dB, -10dB @ 45Hz
<b>COAXIAL DRIVER</b>	LF: 15" (380mm)/3" (75mm) voice coil, long excursion, shared ferrite motor system with HF HF: 1.4" (36mm) exit/3" (75mm) voice coil, titanium dome compression driver
<b>RATED POWER (2)</b>	400W AES, 1600W peak
<b>SENSITIVITY (8)</b>	100dB
<b>MAXIMUM SPL (9)</b>	126dB continuous, 132dB peak
<b>NOMINAL IMPEDANCE</b>	8 ohms
<b>DISPERSION (-6dB)</b>	100°-60° horizontal, 60° vertical (user-rotatable)
<b>CONNECTORS</b>	Low profile 20A push-lock
<b>FITTINGS</b>	10 x M8 fly points
<b>DIMENSIONS</b>	(W) 432mm x (H) 685mm x (D) 413mm (W) 17.01ins x (H) 26.97ins x (D) 16.26ins
<b>WEIGHT</b>	26kg (57.32lbs)

# CDD Weatherised and Marine Editions

The CDD Series in black or white is also available in weather-resistant form. Like many systems on the market, CDD-WR loudspeakers and CSX-WR subwoofers are designed for outdoor operation where it will be subject to changing environmental conditions, but sheltered from direct exposure to the elements. Weatherised mounting brackets are also available.

CDD is also available to custom order as a Marine variant, ideally suited to cruise ships and seaside resort applications. It takes the weatherised cabinet and upgrades both the grille and all metal work to stainless steel 316L.

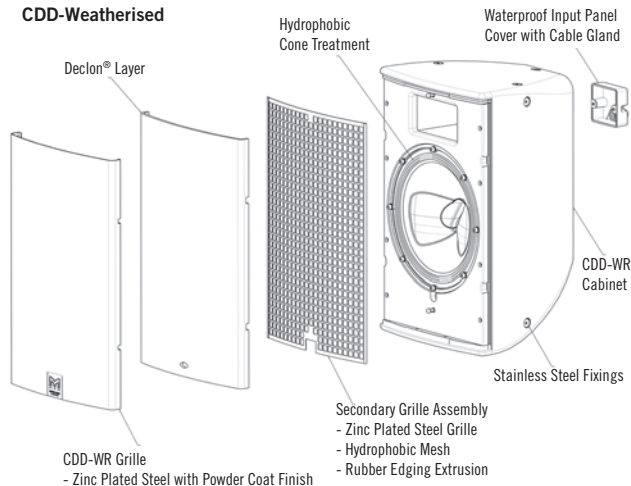



## CDD5TX-WR

WITH LINE TRANSFORMER

<b>TYPE</b>	Ultra-compact, Coaxial Differential Dispersion passive two-way system
<b>FREQUENCY RESPONSE (5)</b>	100Hz-20kHz $\pm$ 3dB, -10dB @ 70Hz
<b>COAXIAL DRIVER</b>	LF: 5.25" (130mm)/1.25" (32mm) voice coil, long excursion, ferrite motor system HF: 0.75" (19mm) voice coil, fabric dome with neodymium motor system
<b>RATED POWER (2)</b>	100W AES, 400W peak
<b>SENSITIVITY (8)</b>	90dB
<b>MAXIMUM SPL (9)</b>	110dB continuous, 116dB peak
<b>NOMINAL IMPEDANCE</b>	8 ohms
<b>DISPERSION (-6dB)</b>	120°-90° horizontal, 80° vertical (user-rotatable)
<b>PROTECTIVE GRILLE</b>	Zinc plated mild steel with powder coated finish and weatherised backing
<b>ENVIRONMENTAL CONNECTORS</b>	Rated at IP54 Low profile 13A push-lock, weatherproof input panel cover with dual cable glands
<b>FITTINGS</b>	6 x M5 inserts for wall/ceiling brackets
<b>DIMENSIONS</b>	(W) 160mm x (H) 230mm x (D) 149mm (W) 6.3ins x (H) 9.1ins x (D) 5.9ins
<b>WEIGHT</b>	3.4kg (7.5lbs)

CDD5 is supplied with wall mount tilt/pan bracket



## CDD8-WR

<b>TYPE</b>	Ultra-compact, Coaxial Differential Dispersion passive two-way system
<b>FREQUENCY RESPONSE (5)</b>	70Hz-20kHz $\pm$ 3dB, -10dB @ 55Hz
<b>COAXIAL DRIVER</b>	LF: 8" (200mm)/2" (50mm) voice coil, long excursion, shared ferrite motor system with HF HF: 1" (25mm) exit/1.4" (38mm) voice coil, polyimide dome compression driver
<b>RATED POWER (2)</b>	200W AES, 800W peak
<b>SENSITIVITY (8)</b>	94dB
<b>MAXIMUM SPL (9)</b>	117dB continuous, 123dB peak
<b>NOMINAL IMPEDANCE</b>	8 ohms
<b>DISPERSION (-6dB)</b>	110°-80° horizontal, 60° vertical (user-rotatable)
<b>PROTECTIVE GRILLE</b>	Zinc plated mild steel with powder coated finish and weatherised backing
<b>ENVIRONMENTAL CONNECTORS</b>	Rated at IP54 Low profile 13A push-lock, weatherproof input panel cover with cable gland
<b>FITTINGS</b>	6 x M6 inserts for wall/ceiling brackets
<b>DIMENSIONS</b>	(W) 256mm x (H) 410mm x (D) 252mm (W) 10.1ins x (H) 16.1ins x (D) 9.9ins
<b>WEIGHT</b>	9.8kg (21.6lbs)



## CDD6TX-WR

WITH LINE TRANSFORMER

<b>TYPE</b>	Ultra-compact, Coaxial Differential Dispersion passive two-way system
<b>FREQUENCY RESPONSE (5)</b>	80Hz-20kHz $\pm$ 3dB, -10dB @ 70Hz
<b>COAXIAL DRIVER</b>	LF: 6.5" (165mm)/1.5" (38mm) voice coil, long excursion, ferrite motor system HF: 1" (25mm) voice coil, fabric dome with neodymium motor system
<b>RATED POWER (2)</b>	150W AES, 600W peak
<b>SENSITIVITY (8)</b>	91dB
<b>MAXIMUM SPL (9)</b>	113dB continuous, 119dB peak
<b>NOMINAL IMPEDANCE</b>	8 ohms
<b>DISPERSION (-6dB)</b>	110°-80° horizontal, 80° vertical (user-rotatable)
<b>PROTECTIVE GRILLE</b>	Zinc plated mild steel with powder coated finish and weatherised backing
<b>ENVIRONMENTAL CONNECTORS</b>	Rated at IP54 Low profile 13A push-lock, weatherproof input panel cover with dual cable glands
<b>FITTINGS</b>	4 x M6 inserts for wall/ceiling brackets
<b>DIMENSIONS</b>	(W) 210mm x (H) 325mm x (D) 210mm (W) 8.3ins x (H) 12.8ins x (D) 8.3ins
<b>WEIGHT</b>	6.5kg (14.3lbs)



## CDD8TX-WR

<b>TYPE</b>	Ultra-compact, Coaxial Differential Dispersion passive two-way system
<b>FREQUENCY RESPONSE (5)</b>	70Hz-20kHz $\pm$ 3dB, -10dB @ 55Hz
<b>COAXIAL DRIVER</b>	LF: 8" (200mm)/2" (50mm) voice coil, long excursion, shared ferrite motor system with HF HF: 1" (25mm) exit/1.4" (38mm) voice coil, polyimide dome compression driver
<b>RATED POWER (2)</b>	200W AES, 800W peak
<b>TRANSFORMER SETTINGS</b>	100V/70V line: 120W, 60W, 30W, 15W
<b>SENSITIVITY (8)</b>	94dB
<b>MAXIMUM SPL (9)</b>	117dB continuous, 123dB peak
<b>NOMINAL IMPEDANCE</b>	8 ohms
<b>DISPERSION (-6dB)</b>	110°-80° horizontal, 60° vertical (user-rotatable)
<b>PROTECTIVE GRILLE</b>	Zinc plated mild steel with powder coated finish and weatherised backing
<b>ENVIRONMENTAL CONNECTORS</b>	Rated at IP54 Low profile 13A push-lock, weatherproof input panel cover with cable gland
<b>FITTINGS</b>	6 x M6 inserts for wall/ceiling brackets
<b>DIMENSIONS</b>	(W) 256mm x (H) 410mm x (D) 252mm (W) 10.1ins x (H) 16.1ins x (D) 9.9ins
<b>WEIGHT</b>	11.4kg (25.13lbs)



## CDD10-WR

TYPE	Compact, Coaxial Differential Dispersion passive two-way system
FREQUENCY RESPONSE (2)	65Hz-20kHz $\pm$ 3dB, -10dB @ 55Hz
COAXIAL DRIVER	LF: 10" (250mm)/2.5" (63.5mm) voice coil, long excursion, shared ferrite motor system with HF HF: 1" (25mm) exit/1.4" (38mm) voice coil, polyimide dome compression driver
RATED POWER (2)	250W AES, 1000W peak
SENSITIVITY (8)	96dB
MAXIMUM SPL (9)	120dB continuous, 126dB peak
NOMINAL IMPEDANCE	8 ohms
DISPERSION (-6dB)	110°-75° horizontal, 60° vertical (user-rotatable)
PROTECTIVE GRILLE	Zinc plated mild steel with powder coated finish and weatherised backing
ENVIRONMENTAL CONNECTORS	Rated at IP54 Low profile 20A push-lock, weatherproof input panel cover with cable gland
FITTINGS	6 x M8 inserts for wall/ceiling brackets, 10 x M8 fly points
DIMENSIONS	(W) 323mm x (H) 513mm x (D) 310mm (W) 12.7ins x (H) 20.2ins x (D) 12.2ins
WEIGHT	15.5kg (34.2lbs)



## CDD12-WR

TYPE	Compact, high-output, Coaxial Differential Dispersion passive two-way system
FREQUENCY RESPONSE (5)	62Hz-20kHz $\pm$ 3dB, -10dB @ 50Hz
COAXIAL DRIVER	LF: 12" (300mm)/2.5" (63.5mm) voice coil, long excursion, shared ferrite motor system with HF HF: 1" (25mm) exit/1.7" (44mm) voice coil, polyimide dome compression driver
RATED POWER (2)	300W AES, 1200W peak
SENSITIVITY (8)	97dB
MAXIMUM SPL (9)	122dB continuous, 128dB peak
NOMINAL IMPEDANCE	8 ohms
DISPERSION (-6dB)	110°-60° horizontal, 60° vertical (user-rotatable)
PROTECTIVE GRILLE	Zinc plated mild steel with powder coated finish and weatherised backing
ENVIRONMENTAL CONNECTORS	Rated at IP54 Low profile 20A push-lock, weatherproof input panel cover with cable gland
FITTINGS	6 x M8 inserts for wall/ceiling brackets, 10 x M8 fly points
DIMENSIONS	(W) 360mm x (H) 571mm x (D) 350mm (W) 14.2ins x (H) 22.5ins x (D) 13.8ins
WEIGHT	19.8kg (43.65lbs)



## CDD10TX-WR

TYPE	Compact, Coaxial Differential Dispersion passive two-way system
FREQUENCY RESPONSE (2)	65Hz-20kHz $\pm$ 3dB, -10dB @ 55Hz
COAXIAL DRIVER	LF: 10" (250mm)/2.5" (63.5mm) voice coil, long excursion, shared ferrite motor system with HF HF: 1" (25mm) exit/1.4" (38mm) voice coil, polyimide dome compression driver
RATED POWER (2)	250W AES, 1000W peak
TRANSFORMER SETTINGS	100V/70V line: 120V, 60W, 30W, 15W
SENSITIVITY (8)	96dB
MAXIMUM SPL (9)	120dB continuous, 126dB peak
NOMINAL IMPEDANCE	8 ohms
DISPERSION (-6dB)	110°-75° horizontal, 60° vertical (user-rotatable)
PROTECTIVE GRILLE	Zinc plated mild steel with powder coated finish and weatherised backing
ENVIRONMENTAL CONNECTORS	Rated at IP54 Low profile 20A push-lock, weatherproof input panel cover with cable gland
FITTINGS	6 x M8 inserts for wall/ceiling brackets, 10 x M8 fly points
DIMENSIONS	(W) 323mm x (H) 513mm x (D) 310mm (W) 12.7ins x (H) 20.2ins x (D) 12.2ins
WEIGHT	17.1kg (37.73lbs)



## CDD15-WR

TYPE	High-output, Coaxial Differential Dispersion passive two-way system
FREQUENCY RESPONSE (5)	55Hz-18kHz $\pm$ 3dB, -10dB @ 45Hz
COAXIAL DRIVER	LF: 15" (380mm)/3" (75mm) voice coil, long excursion, shared ferrite motor system with HF HF: 1.4" (36mm) exit/3" (75mm) voice coil, titanium dome compression driver
RATED POWER (2)	400W AES, 1600W peak
SENSITIVITY (8)	100dB
MAXIMUM SPL (9)	126dB continuous, 132dB peak
NOMINAL IMPEDANCE	8 ohms
DISPERSION (-6dB)	100°-60° horizontal, 60° vertical (user-rotatable)
PROTECTIVE GRILLE	Zinc plated mild steel with powder coated finish and weatherised backing
ENVIRONMENTAL CONNECTORS	Rated at IP54 Low profile 20A push-lock, weatherproof input panel cover with cable gland
FITTINGS	10 x M8 fly points
DIMENSIONS	(W) 429mm x (H) 691mm x (D) 413mm (W) 16.9ins x (H) 27.2ins x (D) 16.3ins
WEIGHT	28.3kg (62.4lbs)



# BlacklineX Series

With BlacklineX, Martin Audio's R&D team has engineered a classic suite of passive loudspeakers for the modern era.

Delivering our signature sound of warmth, nuance and clarity at a price point not previously possible, BlacklineX is a clean, smart design with no-compromise between the needs of installation and portability. Applications range from portable sound reinforcement and stage monitoring for live bands, DJ's and corporate events, to installations in nightclubs, bars, commercial spaces and HoW [House of Worship].

Comprising four two-way systems — from the ultra-compact X8 to the powerful X15 — and three subwoofers, including an unobtrusive slimline model, the multi-purpose BlacklineX Series raises the performance of loudspeaker systems in its class to a new level.

BlacklineX can also be supplemented with the Blackline+ high power performance loudspeakers and subwoofer, ideally suited for thumping club performance and large scale installations.



## X8

TYPE	Ultra-compact, passive two-way system
FREQUENCY RESPONSE (5)	70Hz-20kHz $\pm$ 3dB -10dB @ 60Hz
DRIVERS	LF: 8" (200mm)/2" (50mm) voice coil, ferrite motor system HF: 1" (25mm) exit/1" (25mm) voice coil, polyester dome compression driver
RATED POWER (2)	200W AES, 800W peak
SENSITIVITY (8)	92dB
MAXIMUM SPL (9)	115dB continuous, 121dB peak
NOMINAL IMPEDANCE	8 ohms
DISPERSION (-6dB)	90° H x 50° V (user-rotatable)
CONNECTORS	2 x NL4 type
FITTINGS	13 x M8, 6 x M6 inserts, pole-mount socket, 1 x pocket handle
DIMENSIONS	(W) 257mm x (H) 422mm x (D) 243mm (W) 10.1ins x (H) 16.6ins x (D) 9.6ins
WEIGHT	8kg (17.6lbs)



## X12

TYPE	Compact, passive two-way system
FREQUENCY RESPONSE (5)	62Hz-20kHz $\pm$ 3dB -10dB @ 50Hz
DRIVERS	LF: 12" (300mm)/2.5" (63.5mm) voice coil, ferrite motor system HF: 1" (25mm) exit/1.7" (44mm) voice coil, polyimide dome compression driver
RATED POWER (2)	300W AES, 1200W peak
SENSITIVITY (8)	97dB
MAXIMUM SPL (9)	122dB continuous, 128dB peak
NOMINAL IMPEDANCE	8 ohms
CONNECTORS	2 x NL4 type
FITTINGS	20 x M8 inserts, pole-mount socket, 1 x bar handle
DIMENSIONS	(W) 358mm x (H) 574mm x (D) 337mm (W) 14.1ins x (H) 22.6ins x (D) 13.7ins
WEIGHT	17kg (37.5lbs)



## X10

TYPE	Compact, passive two-way system
FREQUENCY RESPONSE (5)	65Hz-20kHz $\pm$ 3dB -10dB @ 55Hz
DRIVERS	LF: 10" (250mm)/2.5" (63.5mm) voice coil, ferrite motor system HF: 1" (25mm) exit/1.4" (35mm) voice coil, polyimide dome compression driver
RATED POWER (2)	250W AES, 1000W peak
SENSITIVITY (8)	94dB
MAXIMUM SPL (9)	118dB continuous, 124dB peak
NOMINAL IMPEDANCE	8 ohms
CONNECTORS	2 x NL4 type
FITTINGS	19 x M8 inserts, pole-mount socket, 1 x bar handle
DIMENSIONS	(W) 324mm x (H) 522mm x (D) 289mm (W) 12.8ins x (H) 20.6ins x (D) 11.4ins
WEIGHT	14kg (30.9lbs)



## X15

TYPE	High-power, passive two-way system
FREQUENCY RESPONSE (5)	55Hz-20kHz $\pm$ 3dB -10dB @ 45Hz
DRIVERS	LF: 15" (380mm)/3" (75mm) voice coil, ferrite motor system HF: 1" (25mm) exit/1.7" (44mm) voice coil, polyimide dome compression driver
RATED POWER (2)	400W AES, 1600W peak
SENSITIVITY (8)	99dB
MAXIMUM SPL (9)	125dB continuous, 131dB peak
NOMINAL IMPEDANCE	8 ohms
CONNECTORS	2 x NL4 type
FITTINGS	19 x M8 inserts, pole-mount socket, 2 x bar handles
DIMENSIONS	(W) 427mm x (H) 690mm x (D) 419mm (W) 16.8ins x (H) 27.2ins x (D) 16.5ins
WEIGHT	24kg (52.9lbs)



## X115



<b>TYPE</b>	Compact, direct radiating subwoofer
<b>FREQUENCY RESPONSE (1)</b>	45Hz-150Hz ± 3dB -10dB @ 40Hz
<b>DRIVER</b>	15" (380mm)/3" (75mm) voice coil, long excursion, ferrite magnet
<b>RATED POWER (2)</b>	500W AES, 2000W peak
<b>SENSITIVITY (10)</b>	102dB
<b>MAXIMUM SPL (9)</b>	129dB continuous, 135dB peak (half space)
<b>NOMINAL IMPEDANCE</b>	8 ohms
<b>CONNECTORS</b>	3 x NL4 type
<b>FITTINGS</b>	16 x M10 inserts, pole-mount socket 2 x bar handles, provision for castors
<b>DIMENSIONS (INCL FEET)</b>	(W) 465mm x (H) 590mm x (D) 565mm (W) 18.3ins x (H) 23.2ins x (D) 22.2ins
<b>WEIGHT</b>	27kg (59.5lbs)

## X218



<b>TYPE</b>	Dual-driver, direct radiating subwoofer
<b>FREQUENCY RESPONSE (1)</b>	42Hz-200Hz ± 3dB -10dB @ 33Hz
<b>DRIVER</b>	18" (460mm)/4" (100mm) voice coil, long excursion, ferrite magnet
<b>RATED POWER (2)</b>	1600W AES, 6400W peak
<b>SENSITIVITY (10)</b>	106dB
<b>MAXIMUM SPL (9)</b>	141dB peak (half space)
<b>NOMINAL IMPEDANCE</b>	4 ohms
<b>DISPERSION (-6dB)</b>	Omnidirectional
<b>CROSSOVER</b>	80-120Hz active
<b>CONNECTORS</b>	2 x NL4 type
<b>PIN CONNECTIONS (INPUT)</b>	1 + 1- Link Through 2 + 2-
<b>PIN CONNECTIONS (LINK)</b>	1 + 1- Link Through 2 + 2-
<b>FITTINGS</b>	12 x M10 inserts, pole-mount socket 2 x bar handles, 4 x pocket handles, provision for castors
<b>DIMENSIONS (INCL FEET)</b>	(W) 1049mm x (H) 587mm x (D) 727mm (W) 41.3ins x (H) 23.1ins x (D) 28.6ins
<b>WEIGHT</b>	88kg (194lbs)

## X118



<b>TYPE</b>	Compact, direct radiating subwoofer
<b>FREQUENCY RESPONSE (1)</b>	42Hz-150Hz ± 3dB -10dB @ 38Hz
<b>DRIVER</b>	18" (460mm)/3" (75mm) voice coil, long excursion, ferrite magnet
<b>RATED POWER (2)</b>	500W AES, 2000W peak
<b>SENSITIVITY (10)</b>	104dB
<b>MAXIMUM SPL (9)</b>	131dB continuous, 137dB peak (half space)
<b>NOMINAL IMPEDANCE</b>	8 ohms
<b>CONNECTORS</b>	3 x NL4 type
<b>FITTINGS</b>	16 x M10 inserts, pole-mount socket 2 x bar handles, provision for castors
<b>DIMENSIONS (INCL FEET)</b>	(W) 530mm x (H) 669mm x (D) 640mm (W) 20.9ins x (H) 26.3ins x (D) 25.2ins
<b>WEIGHT</b>	33kg (72.7lbs)



# ADORN Series

Martin Audio ADORN on-wall and ceiling loudspeakers bring class-leading performance, reliability and cost competitiveness to a wide range of commercial sound installations — from retail outlets, bars and restaurants to corporate offices.

## Aesthetic Enclosures

ADORN full-range on-wall enclosures are visually unobtrusive with smooth lines. Available in black or white as standard, they can be readily painted to match any interior décor and architectural environment.

ADORN in-ceiling and pendant speakers feature a bezel-less grille for a clean look and a bayonet fitting which is easy to remove without the use of tools. The in-ceiling series is finished in white and may also be painted to blend with any décor while the pendant is also available in black as standard.

## Low Impedance and Transformer Options

All models have a nominal impedance of 16 ohms, enabling four or more speakers to be driven in parallel by one amplifier channel, thereby maximising efficiency and minimising cost.

All 'T' designated models are fitted with an internal high-quality 70V/100V multi-tap line transformer with a switch to select the output level.

## Overload Protection

For full-bandwidth protection, the low and high-frequency sections are individually protected against overload in all models.



## A40

TYPE	Ultra-compact passive two-way system, front ported bass reflex
FREQUENCY RESPONSE (1)	98Hz-17kHz $\pm$ 3dB -10dB @ 70Hz
DRIVERS	LF: 4" /1" high-temp voice coil, coated paper cone, rubber surround ferrite motor, pressed steel chassis HF: 0.75" silk dome, neodymium motor
RATED POWER (2)	40W AES, 160W peak
RECOMMENDED AMPLIFIER	VIA2004
SENSITIVITY (1)	87dB/1W/1m
MAXIMUM SPL (9)	109dB peak
NOMINAL IMPEDANCE	16 ohms
DISPERSION (-6dB)	110° H x 80° V
CROSSOVER	3.5kHz passive (LF and HF auto-resetting fuses)
RECOMMENDED HIGH-PASS FILTER	60Hz 24dB/oct
ENCLOSURE	ABS, UL 94V-0 rated
FINISH	Black or white
FITTINGS	Wall bracket included
DIMENSIONS EXCL. BRACKET	(W) 124mm x (H) 200mm x (D) 114mm (W) 4.9in x (H) 7.9in x (D) 4.5in
WEIGHT	1.75kg (3.9lbs)



## A55

TYPE	Ultra-compact passive two-way system, front ported bass reflex
FREQUENCY RESPONSE (1)	90Hz-17kHz $\pm$ 3dB -10dB @ 65Hz
DRIVERS	LF: 5.25" /1" high-temp voice coil, coated paper cone, rubber surround, ferrite motor, pressed steel chassis HF: 0.75" silk dome, neodymium motor
RATED POWER (2)	50W AES, 200W peak
RECOMMENDED AMPLIFIER	VIA2004
SENSITIVITY (1)	90dB/1W/1m
MAXIMUM SPL (9)	113dB peak
NOMINAL IMPEDANCE	16 ohms
DISPERSION (-6dB)	110° H x 80° V
CROSSOVER	3.5kHz passive (LF and HF auto-resetting fuses)
RECOMMENDED HIGH-PASS FILTER	60Hz 24dB/oct
ENCLOSURE	ABS, UL 94V-0 rated
FINISH	Black or white
FITTINGS	Wall bracket included
DIMENSIONS EXCL. BRACKET	(W) 152mm x (H) 245mm x (D) 140mm (W) 6in x (H) 9.6in x (D) 5.5in
WEIGHT	2.21kg (4.9lbs)



## A40T

TYPE	Ultra-compact passive two-way system, front ported bass reflex
FREQUENCY RESPONSE (1)	98Hz-17kHz $\pm$ 3dB -10dB @ 70Hz
DRIVERS	LF: 4" /1" high-temp voice coil, coated paper cone, rubber surround, ferrite motor, pressed steel chassis HF: 0.75" silk dome, neodymium motor
RATED POWER (2)	40W AES, 160W peak
RECOMMENDED AMPLIFIER	VIA 5002 (In conjunction with suitable line transformer)
SENSITIVITY (1)	87dB/1W/1m
MAXIMUM SPL (9)	109dB peak
NOMINAL IMPEDANCE	16 ohms
DISPERSION (-6dB)	110° H x 80° V
CROSSOVER	3.5kHz passive (LF and HF auto-resetting fuses)
TRANSFORMER TAPS	70V: 20w / 10w / 5w / 2.5w 100V: 20w / 10w / 5w
RECOMMENDED HIGH-PASS FILTER	60Hz 24dB/oct
ENCLOSURE	ABS, UL 94V-0 rated
FINISH	Black or white
FITTINGS	Wall bracket included
DIMENSIONS EXCL. BRACKET	(W) 124mm x (H) 200mm x (D) 114mm (W) 4.9in x (H) 7.9in x (D) 4.5in
WEIGHT	2.13kg (4.7lbs)



## A55T

TYPE	Ultra-compact passive two-way system, front ported bass reflex
FREQUENCY RESPONSE (1)	90Hz-17kHz $\pm$ 3dB -10dB @ 65Hz
DRIVERS	LF: 5.25" /1" high-temp voice coil, coated paper cone, rubber surround, ferrite motor, pressed steel chassis HF: 0.75" silk dome, neodymium motor
RATED POWER (2)	50W AES, 200W peak
RECOMMENDED AMPLIFIER	VIA5002 (In conjunction with suitable line transformer)
SENSITIVITY (1)	90dB/1W/1m
MAXIMUM SPL (9)	113dB peak
NOMINAL IMPEDANCE	16 ohms
DISPERSION (-6dB)	110° H x 80° V
CROSSOVER	3.5kHz passive (LF and HF auto-resetting fuses)
TRANSFORMER TAPS	70V: 30w / 15w / 7.5w / 3.75w 100V: 30w / 15w / 7.5w
RECOMMENDED HIGH-PASS FILTER	60Hz 24dB/oct
ENCLOSURE	ABS, UL 94V-0 rated
FINISH	Black or white
FITTINGS	Wall bracket included
DIMENSIONS EXCL. BRACKET	(W) 152mm x (H) 245mm x (D) 140mm (W) 6in x (H) 9.6in x (D) 5.5in
WEIGHT	2.81kg (6.2lbs)



## ACS-40TS

<b>TYPE</b>	Ultra-compact, passive two-way ceiling speaker, ported bass reflex
<b>FREQUENCY RESPONSE (1)</b>	106Hz-20kHz ± 3dB, -10dB @ 73Hz
<b>DRIVERS</b>	LF: 4" /1" high-temp voice coil, coated paper cone, rubber surround, ferrite motor, pressed steel chassis HF: 0.75" silk dome, neodymium motor
<b>RATED POWER (2)</b>	40W AES, 160W peak
<b>SENSITIVITY (4)</b>	86dB / 1W(4V) / 1m
<b>MAXIMUM SPL (9)</b>	108dB peak
<b>NOMINAL IMPEDANCE</b>	16 ohms
<b>DISPERSION (-6dB)</b>	180° conical up to 10kHz
<b>CROSSOVER</b>	3.5 kHz passive (LF and HF auto-resetting fuses)
<b>TRANSFORMER TAPS</b>	70V: 20w / 10w / 5w / 2.5w, 100V: 20w / 10w / 5w
<b>RECOMMENDED HIGH-PASS FILTER</b>	75Hz 24dB/oct
<b>CONNECTORS</b>	Ceramic connector (in and link) located behind fire-retardant steel cover
<b>ACCESSORIES (included)</b>	2 tile rails, C-ring backing plate, Cut-out template
<b>DIMENSIONS</b>	(OD) 221mm x (D) 98mm (OD) 8.7in x (D) 3.9in
<b>WEIGHT</b>	2.2kg (4.8lbs)



## ACS-55T

<b>TYPE</b>	Compact, passive two-way ceiling speaker, ported bass reflex
<b>FREQUENCY RESPONSE (1)</b>	98Hz-20kHz ± 3dB, -10dB @ 62Hz
<b>DRIVERS</b>	LF: 5.25" /1" high-temp voice coil, coated paper cone, rubber surround, ferrite motor, pressed steel chassis HF: 0.75" silk dome, neodymium motor
<b>RATED POWER (2)</b>	50W AES, 200W peak
<b>SENSITIVITY (4)</b>	90dB / 1W(4V) / 1m
<b>MAXIMUM SPL (9)</b>	113dB peak
<b>NOMINAL IMPEDANCE</b>	16 ohms
<b>DISPERSION (-6dB)</b>	150° conical up to 7kHz
<b>CROSSOVER</b>	3kHz passive (LF and HF auto-resetting fuses)
<b>TRANSFORMER TAPS</b>	70V: 30w / 15w / 7.5w / 3.75w, 100V: 30w / 15w / 7.5w
<b>RECOMMENDED HIGH-PASS FILTER</b>	65Hz 24dB/oct
<b>CONNECTORS</b>	Ceramic connector (in and link) located behind fire-retardant steel cover
<b>ACCESSORIES (included)</b>	2 tile rails, C-ring backing plate, Cut-out template
<b>DIMENSIONS</b>	(OD) 245mm x (D) 193mm (OD) 9.7in x (D) 7.6in
<b>WEIGHT</b>	3kg (6.6lbs)



## ACS-55TS

<b>TYPE</b>	Compact, passive two-way ceiling speaker, ported bass reflex
<b>FREQUENCY RESPONSE (1)</b>	117Hz-20kHz ± 3dB, -10dB @ 79Hz
<b>DRIVERS</b>	LF: 5.25" /1" high-temp voice coil, coated paper cone, rubber surround, ferrite motor, pressed steel chassis HF: 0.75" silk dome, neodymium motor
<b>RATED POWER (2)</b>	50W AES, 200W peak
<b>SENSITIVITY (4)</b>	90dB / 1W(4V) / 1m
<b>MAXIMUM SPL (9)</b>	113dB peak
<b>NOMINAL IMPEDANCE</b>	16 ohms
<b>DISPERSION (-6dB)</b>	150° conical up to 7kHz
<b>CROSSOVER</b>	3kHz passive (LF and HF auto-resetting fuses)
<b>TRANSFORMER TAPS</b>	70V: 30w / 15w / 7.5w / 3.75w, 100V: 30w / 15w / 7.5w
<b>RECOMMENDED HIGH-PASS FILTER</b>	65Hz 24dB/oct
<b>CONNECTORS</b>	Ceramic connector (in and link) located behind fire-retardant steel cover
<b>ACCESSORIES (included)</b>	2 tile rails, C-ring backing plate, Cut-out template
<b>DIMENSIONS</b>	(OD) 245mm x (D) 102mm (OD) 9.7in x (D) 4in
<b>WEIGHT</b>	2.8kg (6.2lbs)



## ACP-55T

<b>TYPE</b>	Passive two-way pendant speaker, ported bass reflex
<b>FREQUENCY RESPONSE (6)</b>	98Hz-20kHz ± 3dB -10dB @ 56Hz
<b>DRIVERS</b>	LF: 5.25" /1" high-temp voice coil, coated paper cone, rubber surround, ferrite motor, pressed steel chassis HF: 0.75" silk dome, neodymium motor
<b>RATED POWER (2)</b>	50W AES, 200W peak
<b>SENSITIVITY (7)</b>	86dB / 1W(4V) / 1m (full space)
<b>MAXIMUM SPL (9)</b>	109dB Peak
<b>NOMINAL IMPEDANCE</b>	16 ohms
<b>DISPERSION (-6dB)</b>	150° conical up to 7kHz
<b>CROSSOVER</b>	3kHz passive (LF and HF auto-resetting fuses)
<b>TRANSFORMER TAPS</b>	70V: 30w / 15w / 7.5w / 3.75w 100V: 30w / 15w / 7.5w
<b>CONNECTORS</b>	Ceramic connector (in and link)
<b>DIMENSIONS</b>	(OD) 246mm x (D) 157mm (175mm including grille) (OD) 9.7in x (D) 6.2in (6.9in including grille)
<b>WEIGHT</b>	3.46kg (7.62lbs)







Westminster Abbey, London, UK

## Electronics

Top quality loudspeakers require top quality amplification and control, and Martin Audio offer just that in the iKON and VIA Series of high-performance, lightweight, power amplifiers, and DX Controllers.

With Martin Audio's enviable reputation for producing loudspeakers with excellent performance and high durability it is no surprise that our name appears on an equally prestigious range of high quality amplifiers and controllers.

With models suited to both touring and installed audio environments our electronic audio components supply the uncompromising sonic performance and unquestionable reliability required by the most demanding of today's sound reinforcement applications. Martin Audio Electronics – completing the circuit.

## iK81



<b>TYPE</b>	Eight-channel Class D amplifier
<b>TOTAL OUTPUT POWER</b>	10,000 Watts RMS, all channels driven
<b>DIGITAL SIGNAL PROCESSING</b>	96kHz DSP on all inputs and outputs
<b>COOLING</b>	Dual vari-speed fans, front-to-back airflow
<b>MAXIMUM AMBIENT TEMPERATURE</b>	40°C (104°F)
<b>ANALOGUE IN/LINK (4 CHANNELS)</b>	4 x female, 4 x male Neutrik™ XLR
<b>ANALOGUE INPUT IMPEDANCE</b>	20kΩ balanced to ground
<b>MAXIMUM ANALOGUE INPUT LEVEL</b>	+20dBu
<b>NOMINAL SYSTEM GAIN</b>	32dB
<b>AES3 IN/LINK (2 CHANNELS)</b>	1 x female, 1 x male Neutrik™ XLR, balanced
<b>DANTE™ (4 CHANNELS)</b>	2 x shielded RJ45, primary and secondary
<b>AMPLIFIER OUTPUTS</b>	4 x Neutrik Speakon™ NL4
<b>PROTOCOL</b>	Ethernet
<b>CONTROL APPLICATION</b>	Martin Audio VU-NET™
<b>TYPE</b>	High performance Series Resonant
<b>AC INPUT OPERATING RANGE</b>	85 – 240V ~ AC, 47 - 63Hz
<b>MAINS INRUSH CURRENT</b>	6A at 115V, 12A at 230V (max for <10ms)
<b>MAINS CONNECTOR</b>	Neutrik 32A Powercon™
<b>DIMENSIONS</b>	(W) 482 x (H) 2U/88mm x (D) 441mm (W) 18.98in x (H) 2U/3.46in x (D) 17.35in incl handles and optional rear support
<b>WEIGHT</b>	12.5kg (27.5lbs)



Aylesbury Waterside Theatre, UK

## iK42



<b>TYPE</b>	Four-channel Class D amplifier
<b>TOTAL OUTPUT POWER</b>	20,000 Watts RMS, all channels driven
<b>DIGITAL SIGNAL PROCESSING</b>	96kHz DSP on all inputs and outputs
<b>COOLING</b>	Dual vari-speed fans, front-to-back airflow
<b>MAXIMUM AMBIENT TEMPERATURE</b>	40°C (104°F)
<b>ANALOGUE IN/LINK (4 CHANNELS)</b>	4 x female, 4 x male Neutrik™ XLR
<b>ANALOGUE INPUT IMPEDANCE</b>	20kΩ balanced to ground
<b>MAXIMUM ANALOGUE INPUT LEVEL</b>	+20dBu
<b>NOMINAL SYSTEM GAIN</b>	32dB
<b>AES3 IN/LINK (2 CHANNELS)</b>	1 x female, 1 x male Neutrik™ XLR, balanced
<b>DANTE™ (4 CHANNELS)</b>	2 x shielded RJ45, primary and secondary
<b>AMPLIFIER OUTPUTS</b>	4 x Neutrik Speakon™ NL4
<b>PROTOCOL</b>	Ethernet
<b>CONTROL APPLICATION</b>	Martin Audio VU-NET™
<b>TYPE</b>	High performance Series Resonant
<b>AC INPUT OPERATING RANGE</b>	85 – 240V ~ AC, 47 - 63Hz
<b>MAINS INRUSH CURRENT</b>	6A at 115V, 12A at 230V (max for <10ms)
<b>MAINS CONNECTOR</b>	Neutrik 32A Powercon™
<b>DIMENSIONS</b>	(W) 482 x (H) 2U/88mm x (D) 441mm (W) 18.98in x (H) 2U/3.46in x (D) 17.35in incl handles and optional rear support
<b>WEIGHT</b>	12.5kg (27.5lbs)

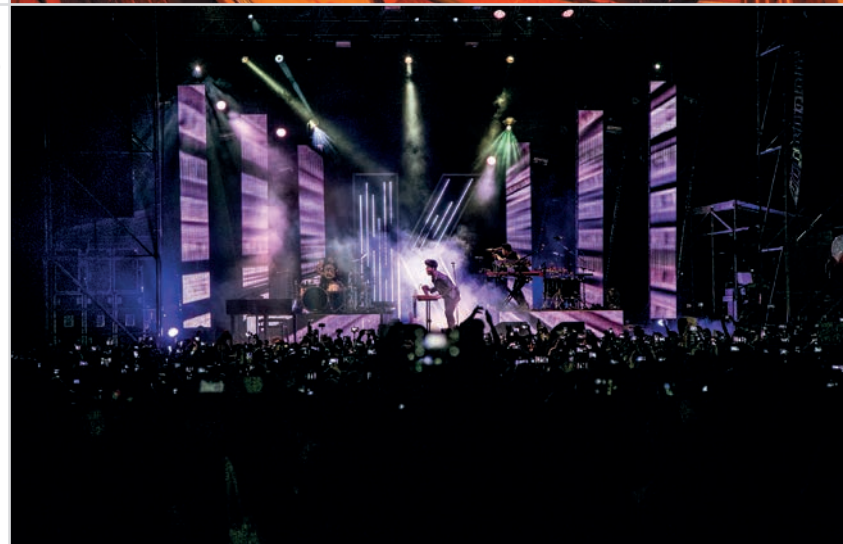

## VIA2004



<b>General</b>	
TYPE	Four-channel Class D amplifier
POWER OUTPUT**	4 x 500W into 4 ohms 4 x 250W into 8 ohms
<b>COOLING</b>	
MAXIMUM AMBIENT TEMPERATURE	40°C (105°F)
Audio Inputs/Outputs	
ANALOGUE IN/LINK (4 CHANNELS)	4 x female, 4 x male Neutrik™ XLR
ANALOGUE INPUT IMPEDANCE	5 kΩ typical, balanced
MAXIMUM ANALOGUE INPUT LEVEL	+20dBu
AMPLIFIER OUTPUTS	4 x Neutrik Speakon™ NL4
<b>Audio Performance</b>	
FREQUENCY RESPONSE	20Hz - 20kHz +/- 0.45dB, 4 ohm load
TOTAL HARMONIC DISTORTION	0.003% typical, 1kHz @ 1W
<b>Power Supplies</b>	
TYPE	2 x high current, high frequency, switch-mode
AC INPUT OPERATING RANGE	100-240V +/-10%, 45 - 65Hz
MAINS CONNECTOR	1 x Neutrik Powercon™
TOTAL SYSTEM EFFICIENCY	89% (4 x 250W into 8 ohms)
<b>Physical</b>	
DIMENSIONS	(W) 482 x (H) 2U/88mm x (D) 441mm (W) 19in x (H) 2U/3.5in x (D) 17.4in incl handles and optional rear support
WEIGHT	8kg (17.6lbs)

## VIA2502



<b>General</b>	
TYPE	Two-channel Class D amplifier
POWER OUTPUT**	2 x 1250W into 2 ohms 2 x 800W into 4 ohms 2 x 450W into 8 ohms 1 x 2500W bridged into 4 ohms
<b>COOLING</b>	
MAXIMUM AMBIENT TEMPERATURE	40°C (105°F)
Audio Inputs/Outputs	
ANALOGUE IN/LINK (4 CHANNELS)	2 x female, 2 x male Neutrik™ XLR
ANALOGUE INPUT IMPEDANCE	10kΩ Balanced
MAXIMUM ANALOGUE INPUT LEVEL	+20dBu
AMPLIFIER OUTPUTS	2 x Neutrik Speakon™ NL4
<b>Audio Performance</b>	
OUTPUT NOISE	-113dBa, referenced to max output (22kHz bandwidth)
FREQUENCY RESPONSE	< 10Hz - > 20kHz +/- 0.25dB
TOTAL HARMONIC DISTORTION	< 0.05% typical @ 1kHz, -3dB output (22kHz bandwidth)
SLEW RATE	> 80V per microsecond
DAMPING FACTOR	120 ref 8 ohms
<b>Power Supply</b>	
TYPE	High current, high frequency switch-mode
AC INPUT OPERATING RANGE	100-240V +/-10% 45 - 65Hz
MAINS CONNECTOR	1 x Neutrik Powercon™
<b>Physical</b>	
DIMENSIONS	(W) 482 x (H) 2U/88mm x (D) 441mm (W) 19in x (H) 2U/3.5in x (D) 17.4in incl handles and optional rear support
WEIGHT	8kg (17.6lbs)

## VIA5002



<b>General</b>	
TYPE	Two-channel Class D amplifier
POWER OUTPUT**	2 x 2500W into 4 ohms 2 x 1600W into 8 ohms
<b>COOLING</b>	
	Vari-speed fans, front-to-back airflow
MAXIMUM AMBIENT TEMPERATURE	40°C (105°F)
<b>Audio Inputs/Outputs</b>	
ANALOGUE IN/LINK (4 CHANNELS)	2 x female, 2 x male Neutrik™ XLR
ANALOGUE INPUT IMPEDANCE	10K $\Omega$ balanced
MAXIMUM ANALOGUE INPUT LEVEL	+20dBu
AMPLIFIER OUTPUTS	2 x Neutrik Speakon™ NL4
<b>Audio Performance</b>	
OUTPUT NOISE	-113dBA, referenced to max output (22kHz bandwidth)
FREQUENCY RESPONSE	< 10Hz - > 20kHz +/- 0.25dB
TOTAL HARMONIC DISTORTION	< 0.05% typical @ 1kHz, -3dB output (22kHz bandwidth)
SLEW RATE	> 80V per microsecond
DAMPING FACTOR	120 ref 8 ohms
<b>Power Supplies</b>	
TYPE	2 x high current, high frequency switch-mode
AC INPUT OPERATING RANGE	100-240V +/-10% 45 - 65Hz
TOTAL SYSTEM EFFICIENCY	> 90% typical
MAINS CONNECTOR	1 x Neutrik Powercon™
<b>Physical</b>	
DIMENSIONS	(W) 482 x (H) 2U/88mm x (D) 441mm (W) 19in x (H) 2U/3.5in x (D) 17.4in incl handles and optional rear support
WEIGHT	10kg (22lbs)

## VIA5004



<b>General</b>	
TYPE	Four-channel Class D amplifier
POWER OUTPUT**	4 x 1250W into 2 ohms 4 x 800W into 4 ohms 4 x 450W into 8 ohms 2 x 2500W bridged into 4 ohms
<b>COOLING</b>	
	Vari-speed fans, front-to-back airflow
MAXIMUM AMBIENT TEMPERATURE	40°C (105°F)
<b>Audio Inputs/Outputs</b>	
ANALOGUE IN/LINK (4 CHANNELS)	4 x female, 4 x male Neutrik™ XLR
ANALOGUE INPUT IMPEDANCE	10K $\Omega$ balanced
MAXIMUM ANALOGUE INPUT LEVEL	+20dBu
AMPLIFIER OUTPUTS	4 x Neutrik Speakon™ NL4
<b>Audio Performance</b>	
OUTPUT NOISE	-113dBA, referenced to max output (22kHz bandwidth)
FREQUENCY RESPONSE	< 10Hz - > 20kHz +/- 0.25dB
TOTAL HARMONIC DISTORTION	< 0.05% typical @ 1kHz, -3dB output (22kHz bandwidth)
SLEW RATE	> 80V per microsecond
DAMPING FACTOR	120 ref 8 ohms
<b>Power Supplies</b>	
TYPE	2 x high current, high frequency switch-mode
AC INPUT OPERATING RANGE	100-240V +/-10% 45 - 65Hz
TOTAL SYSTEM EFFICIENCY	> 90% typical
MAINS CONNECTOR	1 x Neutrik Powercon™
<b>Physical</b>	
DIMENSIONS	(W) 482 x (H) 2U/88mm x (D) 441mm (W) 19in x (H) 2U/3.5in x (D) 17.4in incl handles and optional rear support
WEIGHT	10kg (22lbs)

\*\* Continuous average power per channel, all channels driven with music program material and a nominal ambient temperature of 40°C /105°F

## U-HUB



<b>General</b>	
TYPE	Ethernet to U-NET™ bridge
SUPPORTED PROTOCOLS	Ethernet and U-NET™
CONTROL APPLICATION	Martin Audio VU-NET™
AC OPERATING RANGE	100-240VAC Nominal, 50-60Hz
<b>Rear Panel</b>	
AUDIO INPUTS 1, 2 and 3	3 x 3 pin female XLR type
ETHERNET	1 x Neutrik® Ethercon
MAINS POWER	3 pin IEC with cable locking mechanism
FUSE	User-replaceable 1A T-type 20mm
<b>Front Panel</b>	
AUDIO OUT AND U-NET	6 x ODU 8-pin connector ports Audio In 1, 2, 3, Out on ports 1, 3, 5
UNET STATUS	Bi-colour Green/Red LED on port 1 and 6
IP CONFIGURATION	Yellow LED: On = Static IP, Off = Dynamic
IP RESET (TO DYNAMIC)	Recessed push button
ETHERNET CONNECTION	Green LED = Online
MAINS POWER	Red LED = Mains power present
<b>Physical</b>	
DIMENSIONS	(W) 482mm x (H) 1U/44mm x (D) 268mm (W) 19in x (H) 1U/1.75in x (D) 10.6in
WEIGHT	3.5Kg (7.7lbs)

## DX4.0



<b>General</b>	
TYPE	4 input/8 output digital loudspeaker processor
OPERATING TEMPERATURE	0 to 45°C
HUMIDITY RANGE	0 to 80% RH (non-condensing)
<b>Audio Performance</b>	
INPUT IMPEDANCE	> 10kΩ balanced
OUTPUT IMPEDANCE	< 100Ω balanced
MAX INPUT LEVEL	+20dBu
MAX OUTPUT LEVEL	+18dBu into 600Ω
FREQUENCY RESPONSE	10Hz - 40kHz
INPUT DYNAMIC RANGE	> 120dBa typ.
OUTPUT DYNAMIC RANGE	> 118dBa typ.
TOTAL HARMONIC DISTORTION	< 0.008% typ. 20Hz-20kHz
<b>Digital Signal Processing</b>	
SAMPLE RATE	96kHz
AES3 INPUT SAMPLE RATE	28kHz – 108kHz
AES3 OUTPUT SAMPLE RATE	96kHz
<b>Power Supply</b>	
AC OPERATING RANGE	100-240V +/-10%
POWER CONSUMPTION	30W
<b>Control and Monitoring</b>	
PROTOCOL	Ethernet
CONTROL APPLICATION	Martin Audio VU-NET™
<b>Connectors</b>	
AUDIO INPUT	4 x 3 pin female XLR for analogue or AES3 pairs
AUDIO OUTPUT	8 x 3 pin male XLR for analogue or AES3 pairs
ETHERNET	1 x shielded RJ45
DANTE™ NETWORK	2 x shielded RJ45, primary and secondary
AUX PORT	Phoenix connector for contact closure
MAINS POWER	3 pin IEC
<b>Physical</b>	
DIMENSIONS	(W) 482mm x (H) 1U/44mm x (D) 184mm (W) 19in x (H) 1U/1.75in x (D) 7.2in
WEIGHT	2.7kg (6lbs)

## DX0.5



<b>INPUTS</b>	2 electronically balanced analogue
<b>CMRR</b>	> 58dB
<b>OUTPUTS</b>	6 electronically balanced analogue
<b>MAX OUTPUT</b>	+ 21dBu
<b>FREQUENCY RESPONSE</b>	20Hz-20kHz $\pm$ 0.2dB
<b>PARAMETRIC EQUALISATION</b>	
<b>FILTERS</b>	5 per input / 7 per output
<b>FILTER GAIN</b>	$\pm$ 15dB in 0.05dB steps
<b>FREQUENCY RANGE</b>	20Hz - 20kHz, 1/24 octave steps
<b>FILTER BW</b>	3 to 0.05 in 0.05 steps
<b>HIGH AND LOWPASS FILTERS</b>	
<b>FREQUENCY RANGE</b>	20Hz - 20kHz
<b>RESPONSES</b>	
Butterworth	6dB, 12dB, 18dB, 24dB / Octave
Linkwitz-Riley	12dB, 24dB / Octave
Bessel	12dB, 24dB / Octave
<b>LIMITERS</b>	
<b>THRESHOLD</b>	+ 20dBu to -10dBu
<b>ATTACK TIME</b>	5ms to 200ms
<b>RELEASE TIME</b>	0.1 – 3.0s $\pm$ 0.1s increments
<b>DISPLAY</b>	2 x 24 character blue LCD
<b>INPUT METER</b>	2 x 7 point, -20dB to + 15dB
<b>OUTPUT METER</b>	6 x 7 point, -15dB to + 15dB into limit
<b>CONNECTORS</b>	
<b>INPUTS</b>	3 pin female XLR
<b>OUTPUTS</b>	3 pin male XLR
<b>POWER</b>	3 pin IEC
<b>POWER</b>	100 to 240V @ 50/60Hz
<b>CONSUMPTION:</b>	40 watts
<b>DIMENSIONS</b>	(W) 482mm x (H) 44mm x (D) 229mm (W) 19ins x (H) 1.75ins (1U) x (D) 9ins
<b>WEIGHT</b>	2.6kg (5.8lbs)





Đơn vị nhập khẩu chính thức Martin Audio tại Việt Nam

**DUC PROAUDIO CO.,LTD**

Nhà phân phối chính thức phía Bắc

**MTA ELEC CO., LTD**

Add: No LK 01-23, An Hung, Duong Noi,

Ha Dong District, Ha Noi.

SĐT: 0869 83 68 68

